

01474 53 54 56

www.airbrakeconnections.co.uk

sales@airbrakeconnections.co.uk

“FITTING YOUR EVERY NEED”



CONTENT SECTIONS

1 SIRIT AIR BRAKE FITTINGS



2 COMPRESSION FITTINGS



3 NYLON DIN SPEC TUBING



4 PNEUFIT NORGREN FITTINGS



5 AIR TANKS & ACCESSORIES



6 NORGREN FLEETFIT FITTINGS



7 COILS & ADAPTORS (AIR & ELECTRICAL)



8 GREASE NIPPLES - CLIPS - CLAMPS



9 MALLEABLE IRON FITTINGS



10 MARKER BOARDS & RELECTIVE TAPE





CONTENT SECTIONS

11 NORGREN COMPOSITE FITTINGS



12 BRAKE PIPE FITTINGS & CUNIFER PIPE



13 JOHN GUEST PLASTIC



14 BRASS COMPRESSION



15 PCL - WORKSHOP FITTINGS & ACCESSORIES



16 HOSE - TUBING - CUTTERS



17 RAUFOSS ABC PUSH IN SYSTEM



18 COUPLINGS - VALVES - TEST EQUIPMENT



19 SIRIT BRASS RELEASABLE FITTING SYSTEM



Display pack information is found at the back of the catalogue for all your racking needs





Established June 1992. Air Brake Connections set out to specialise in the distribution of Air Brake Fittings and ancillary items for the commercial vehicle industry throughout Europe. Our main aim over the many years has been to provide the best service and forever expanding product range that is available. We appreciate the importance of product control and are therefore ISO 9001:2015 Registered.



We are distributors of the SIRIT Modular Push in System (UK Sole Distributors), which is TUV approved and standard fit to the majority of OEM trailer manufacturers.

ABC Ltd also specialise in the assembly of push in fitting kits to suit individual trailer manufacturers needs. We supply a variety of kits in many forms, all tailor made to suit the builders specific needs.

We pride ourselves at Air Brake Connections on having over 35 years experience within the truck & trailer market and offering products of the highest quality at the most competitive prices.

Our aim is to meet all of our customer's needs and offer a fast and efficient service, which is second to none, we try our very best to fulfill all orders and provide a next day delivery service .(UK Mainland Only) with upgrade options available.

All our staff are fully trained so please do not hesitate in contacting us with any of your requirements. If it's details of a single fitting, to a layout of a trailer kit, we are here to help.



We carry large stocks of Air Brake fittings, both Compression and Push in, Nylon Tubing, Air Brake Hose, Rubber Hose, Marker Boards, Air Reservoirs Malleable Iron, Air Brake, Electrical Coils, and much more.

ABOUT US



SECTION

1



TUV SIRIT MODULAR AIR BRAKE FITTINGS

SCOPE OF USE

The **SIRIT** brass instantaneous push-in fitting has been designed to be used with (Rilsan) 11/12 polyamide or (Hytrel) elastomeric polyester tubings on the pneumatic circuits of auxiliary and braking systems on trucks and trailers.

It is a ready-to-use safety fitting that does not require additional tools or equipment for coupling with the tubing's.

The only operation required is the manual insertion of the tubing in the seat of the fitting.

This makes for a much shorter assembly time than with traditional cutting ring-type couplings.

Assembly time are estimated to be 70%÷80% shorter.

The tolerance of the used tubing must comply strictly with those set forth in **ISO standard 7628** and **DIN standard 74324/73378**.

The operating heat range for the SIRIT instantaneous fitting is : **+100°C / -40°C**.

The seal in these conditions is ensured by means of a specific design mix selected for the SIRIT O-Ring.

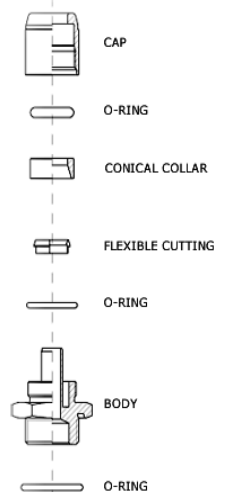

The **SIRIT** fittings for braking systems comply with **DIN 2353** regulation. The types of fittings shown in this catalogue are based on the requests made by the main European braking systems installers.

The range which is particularly extensive, is able to satisfy the requirements of truck, trailers and semi-trailers builders as well as those of transformers and spare parts dealers. The working pressures are within the average - low pressure values and correspond to those stated for the light series (L) of **DIN 2353**.

The SIRIT fittings for braking systems can also be used on oil-pressure circuits as long as the pressure **does not exceed 250 atm**.

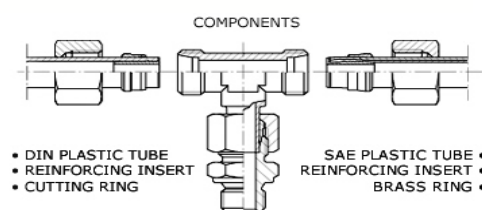



ASSEMBLY INSTRUCTIONS

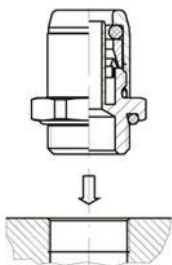

The seal of the stud coupling is specified by what is laid down in ISO standard 6149-80 and DIN standard 3482. To obtain the correct assembly on all terminal fittings it is essential to adhere to the tightening torques shown in the following table:

Thread	Tightening Torque (Nm) ± 10
M10 x 1	22
M12 x 1.5	24
M14 x 1.5	30
M16 x 1.5	35
M18 x 1.5	36
M22 x 1.5	40
M26 x 1.5	45

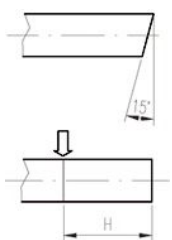

The tubing must be cut at the right angles with a maximum tolerance of 15°. Correct assembly is performed only when the tubing is inserted touches the end of the tube seat. To be absolutely certain that this is the case it is advisable to mark the depth of the tubing coupling (distance H).

Ø Pipe (mm)	Fitting Force (H)
M10 x 1	22
M12 x 1.5	24
M14 x 1.5	30
M16 x 1.5	35
M18 x 1.5	36
M22 x 1.5	40
M26 x 1.5	45

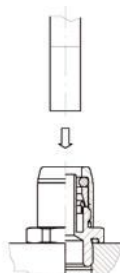

Ø Pipe (mm)	Depth of Coupling (H)
6 x 4	19,8
8 x 6	20,5
10 x 7	24
10 x 7.5	24
10 x 8	24
12 x 9	25
15 x 12	27
16 x 12	27
18 x 14	27

The tubing/fitting coupling does not require tools. To make the operation easier it is sufficient to slightly turn the tubing. The force required for the fitting is shown in the following table.

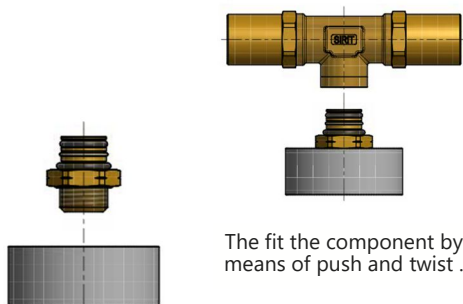

Screw the swivel Coupling into the thread ensuring the correct torque (Over-tightening can cause damage to both the fitting

The fit the component by means of push and twist.

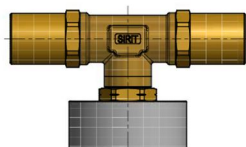

IMPORTANT:
Check the component is coupled correctly and securely.
Pull the component to ensure in this case.

TUV CERTIFICATE

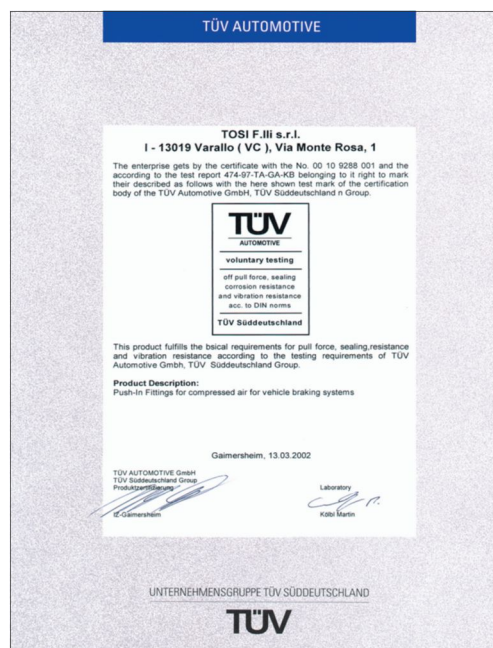

The Dimensions shown in the tables in the catalogue are only shown as a guide. We reserve the right to make any due alteration when required for technical reasons.

800 SERIES MALE STUD COUPLINGS



Part Ref	Thread Size	Tube Size (mm)
----------	-------------	----------------

800202	1/8"	6 x 1
800204	1/4"	6 x 1
800210	M10 x 1	6 x 1
800212	M12 x 1.5	6 x 1
800212/1	M12 x 1	6 x 1
800214	M14 x 1.5	6 x 1
800216	M16 x 1.5	6 x 1
800222	M22 x 1.5	6 x 1

800302	1/8"	8 x 1
800304	1/4"	8 x 1
800310	M10 x 1	8 x 1
800312	M12 x 1.5	8 x 1
800314	M14 x 1.5	8 x 1
800316	M16 x 1.5	8 x 1
800322	M22 x 1.5	8 x 1

800404	1/4"	10 x 1.25
800410	M10 x 1	10 x 1.25
800412\1	M12 x 1.5	10 x 1
800412	M12 x 1.5	10 x 1.25
800412/5	M12 x 1.5	10 x 1.5
800414	M14 x 1.5	10 x 1.25
800416/1	M16 x 1.5	10 x 1
800416	M16 x 1.5	10 x 1.25
800416/5	M16 x 1.5	10 x 1.5

Part Ref	Thread Size	Tube Size (mm)
----------	-------------	----------------

800422/1	M22 x 1.5	10 x 1
800422	M22 x 1.5	10 x 1.25
800422/5	M22 x 1.5	10 x 1.5

800504	1/4"	12 x 1.5
800512	M12 x 1.5	12 x 1.5
800514	M14 x 1.5	12 x 1.5
800516	M16 x 1.5	12 x 1.5
800522	M22 x 1.5	12 x 1.5

800616	M16 x 1.5	15 x 1.5
800622	M22 x 1.5	15 x 1.5
800626	M26 x 1.5	15 x 1.5

800716	M16 x 1.5	16 x 2
800722	M22 x 1.5	16 x 2

800816	M16 x 1.5	18 x 2
800822	M22 x 1.5	18 x 2
800826	M26 x 1.5	18 x 2

800902	1/8"	9 x 1.5
800904	1/4"	9 x 1.5
800910	M10 x 1	9 x 1.5
800912	M12 x 1.5	9 x 1.5
800916	M16 x 1.5	9 x 1.5
800922	M22 x 1.5	9 x 1.5

8001112	M12 x 1.5	11 x 1.5
8001116	M16 x 1.5	11 x 1.5
8001122	M22 x 1.5	11 x 1.5



810 SERIES STUD ELBOWS



Part Ref	Thread Size	Tube Size (mm)
810210	M10 x 1	6 x 1
810212	M12 x 1.5	6 x 1
810214	M14 x 1.5	6 x 1
810216	M16 x 1.5	6 x 1
810222	M22 x 1.5	6 x 1
810310	M10 x 1	8 x 1
810312	M12 x 1.5	8 x 1
810314	M14 x 1.5	8 x 1
810316	M16 x 1.5	8 x 1
810322	M22 x 1.5	8 x 1
810410	M10 x 1	10 x 1.25
810412	M12 x 1.5	10 x 1.25
810414	M14 x 1.5	10 x 1.25
810416	M16 x 1.5	10 x 1.25
810422	M22 x 1.5	10 x 1.25
810512	M12 x 1.5	12 x 1.5
810514	M14 x 1.5	12 x 1.5
810516	M16 x 1.5	12 x 1.5
810522	M22 x 1.5	12 x 1.5
810616	M16 x 1.5	15 x 1.5
810622	M22 x 1.5	15 x 1.5
810716	M16 x 1.5	16 x 2
810722	M22 x 1.5	16 x 2
810816	M16 x 1.5	18 x 2
810822	M22 x 1.5	18 x 2

820 SERIES STUD RUN TEES



Part Ref	Thread Size	Tube Size (mm)
820210	M10 x 1	6 x 1
820212	M12 x 1.5	6 x 1
820216	M16 x 1.5	6 x 1
820222	M22 x 1.5	6 x 1
820310	M10 x 1	8 x 1
820312	M12 x 1.5	8 x 1
820316	M16 x 1.5	8 x 1
820322	M22 x 1.5	8 x 1
820410	M10 x 1	10 x 1.25
820412	M12 x 1.5	10 x 1.25
820416	M16 x 1.5	10 x 1.25
820422	M22 x 1.5	10 x 1.25
820512	M12 x 1.5	12 x 1.5
820516	M16 x 1.5	12 x 1.5
820522	M22 x 1.5	12 x 1.5
820616	M16 x 1.5	15 x 1.5
820622	M22 x 1.5	15 x 1.5
820716	M16 x 1.5	16 x 2
820722	M22 x 1.5	16 x 2
820816	M16 x 1.5	18 x 2
820822	M22 x 1.5	18 x 2

ELBOW AND TEES ALSO AVAILABLE TO 9 mm & 11 mm tube

830 SERIES STUD TEES



Part Ref	Thread Size	Tube Size (mm)
----------	-------------	----------------

830210	M10 x 1	6 x 1
830212	M12 x 1.5	6 x 1
830216	M16 x 1.5	6 x 1
830222	M22 x 1.5	6 x 1

830310	M10 x 1	8 x 1
830312	M12 x 1.5	8 x 1
830316	M16 x 1.5	8 x 1
830322	M22 x 1.5	8 x 1

Part Ref	Thread Size	Tube Size (mm)
----------	-------------	----------------

830410	M10 x 1	10 x 1.25
830412	M12 x 1.5	10 x 1.25
830416	M16 x 1.5	10 x 1.25
830422	M22 x 1.5	10 x 1.25

830512	M12 x 1.5	12 x 1.5
830516	M16 x 1.5	12 x 1.5
830522	M22 x 1.5	12 x 1.5

830616	M16 x 1.5	15 x 1.5
830622	M22 x 1.5	15 x 1.5

830716	M16 x 1.5	16 x 2
830722	M22 x 1.5	16 x 2

830816	M16 x 1.5	18 x 2
830822	M22 x 1.5	18 x 2

840 SERIES 45° STUD ELBOW



Part Ref	Thread Size	Tube Size (mm)
----------	-------------	----------------

840216	M16 x 1.5	6 x 1
840222	M22 x 1.5	6 x 1
840316	M16 x 1.5	8 x 1
840322	M22 x 1.5	8 x 1
840416	M16 x 1.5	10 x 1.25
840422	M22 x 1.5	10 x 1.25
840516	M16 x 1.5	12 x 1.5
840522	M22 x 1.5	12 x 1.5
840616	M16 x 1.5	15 x 1.5
840622	M22 x 1.5	15 x 1.5
840716	M16 x 1.5	16 x 2
840722	M22 x 1.5	16 x 2
840816	M16 x 1.5	18 x 2
840822	M22 x 1.5	18 x 2

841 SERIES FIXED STUD CROSS



Part Ref	Thread Size	Tube Size (mm)
----------	-------------	----------------

841216	M16 x 1.5	6 x 1
841222	M22 x 1.5	6 x 1
841316	M16 x 1.5	8 x 1
841322	M22 x 1.5	8 x 1
841416	M16 x 1.5	10 x 1.25
841422	M22 x 1.5	10 x 1.25
841516	M16 x 1.5	12 x 1.5
841522	M22 x 1.5	12 x 1.5
841616	M16 x 1.5	15 x 1.5
841622	M22 x 1.5	15 x 1.5
841716	M16 x 1.5	16 x 2
841722	M22 x 1.5	16 x 2
841816	M16 x 1.5	18 x 2
841822	M22 x 1.5	18 x 2

842 SERIES FIXED 'Y' STUD ELBOW



Part Ref	Thread Size	Tube Size (mm)
842216	M16 x 1.5	6 x 1
842222	M22 x 1.5	6 x 1
842316	M16 x 1.5	8 x 1
842322	M22 x 1.5	8 x 1

Part Ref	Thread Size	Tube Size (mm)
842416	M16 x 1.5	10 x 1.25
842422	M22 x 1.5	10 x 1.25
842516	M16 x 1.5	12 x 1.5
842522	M22 x 1.5	12 x 1.5
842616	M16 x 1.5	15 x 1.5
842622	M22 x 1.5	15 x 1.5
842716	M16 x 1.5	16 x 2
842722	M22 x 1.5	16 x 2
842816	M16 x 1.5	18 x 2
842822	M22 x 1.5	18 x 2

823 SERIES STUD RUN TEST POINT TEES



Part Ref	Thread Size	Tube Size (mm)
823212	M12 x 1.5	6 x 1
823216	M16 x 1.5	6 x 1
823222	M22 x 1.5	6 x 1
823312	M12 x 1.5	8 x 1
823316	M16 x 1.5	8 x 1
823322	M22 x 1.5	8 x 1

Part Ref	Thread Size	Tube Size (mm)
823412	M12 x 1.5	10 x 1.25
823416	M16 x 1.5	10 x 1.25
823422	M22 x 1.5	10 x 1.25
823512	M12 x 1.5	12 x 1.5
823516	M16 x 1.5	12 x 1.5
823522	M22 x 1.5	12 x 1.5
823616	M16 x 1.5	15 x 1.5
823622	M22 x 1.5	15 x 1.5
823716	M16 x 1.5	16 x 2
823722	M22 x 1.5	16 x 2
823816	M16 x 1.5	18 x 2
823822	M22 x 1.5	18 x 2

831 SERIES STUD TEST POINT TEES

Part Ref	Thread Size	Tube Size (mm)
831212	M12 x 1.5	6 x 1
831216	M16 x 1.5	6 x 1
831222	M22 x 1.5	6 x 1
831312	M12 x 1.5	8 x 1
831316	M16 x 1.5	8 x 1
831322	M22 x 1.5	8 x 1
831412	M12 x 1.5	10 x 1.25
831416	M16 x 1.5	10 x 1.25
831422	M22 x 1.5	10 x 1.25



Part Ref	Thread Size	Tube Size (mm)
831512	M12 x 1.5	12 x 1.5
831516	M16 x 1.5	12 x 1.5
831522	M22 x 1.5	12 x 1.5
831616	M16 x 1.5	15 x 1.5
831622	M22 x 1.5	15 x 1.5
831716	M16 x 1.5	16 x 2
831722	M22 x 1.5	16 x 2
831816	M16 x 1.5	18 x 2
831822	M22 x 1.5	18 x 2

**843 SERIES
FIXED "F" ELBOWS**



Part Ref	Thread Size	Tube Size (mm)
843212	M12 x 1.5	6 x 1
843216	M16 x 1.5	6 x 1
843222	M22 x 1.5	6 x 1
843312	M12 x 1.5	8 x 1
843316	M16 x 1.5	8 x 1
843322	M22 x 1.5	8 x 1
843412	M12 x 1.5	10 x 1.25
843416	M16 x 1.5	10 x 1.25
843422	M22 x 1.5	10 x 1.25
843512	M12 x 1.5	12 x 1.5
843516	M16 x 1.5	12 x 1.5
843522	M22 x 1.5	12 x 1.5
843616	M16 x 1.5	15 x 1.5
843622	M22 x 1.5	15 x 1.5
843716	M16 x 1.5	16 x 2
843722	M22 x 1.5	16 x 2
843816	M16 x 1.5	18 x 2
843822	M22 x 1.5	18 x 2

For the male / female bodies please see page 20

**821 SERIES
STUD RUN TEST POINT TEES**



Part Ref	Thread Size	Tube Size (mm)
821212	M12 x 1.5	6 x 1
821216	M16 x 1.5	6 x 1
821222	M22 x 1.5	6 x 1
821312	M12 x 1.5	8 x 1
821316	M16 x 1.5	8 x 1
821322	M22 x 1.5	8 x 1
821412	M12 x 1.5	10 x 1.25
821416	M16 x 1.5	10 x 1.25
821422	M22 x 1.5	10 x 1.25
821512	M12 x 1.5	12 x 1.5
821516	M16 x 1.5	12 x 1.5
821522	M22 x 1.5	12 x 1.5
821616	M16 x 1.5	15 x 1.5
821622	M22 x 1.5	15 x 1.5
821716	M16 x 1.5	16 x 2
821722	M22 x 1.5	16 x 2
821816	M16 x 1.5	18 x 2
821822	M22 x 1.5	18 x 2

For the male / female bodies please see page 19



-
-
-
-
-

803 SERIES STUD BULKHEADS



Part Ref	Thread Size	Tube Size (mm)	Body (mm)	Thread F Size (mm)
803212	M12 x 1.5	6 x 1	18 x 1.5	12 x 1.5
803216	M16 x 1.5	6 x 1	18 x 1.5	12 x 1.5
803222	M22 x 1.5	6 x 1	18 x 1.5	12 x 1.5
803312	M12 x 1.5	8 x 1	18 x 1.5	12 x 1.5
803316	M16 x 1.5	8 x 1	18 x 1.5	12 x 1.5
803322/16	M22 x 1.5	8 x 1	16 x 1.5	10 x 1
803322	M22 x 1.5	8 x 1	18 x 1.5	12 x 1.5
803412	M12 x 1.5	10 x 1.25	18 x 1.5	12 x 1.5
803416	M16 x 1.5	10 x 1.25	18 x 1.5	12 x 1.5
803422/16	M22 x 1.5	10 x 1.25	16 x 1.5	10 x 1
803422	M22 x 1.5	10 x 1.25	18 x 1.5	12 x 1.5
803512	M12 x 1.5	12 x 1.5	18 x 1.5	12 x 1.5
803516	M16 x 1.5	12 x 1.5	18 x 1.5	12 x 1.5
803522	M22 x 1.5	12 x 1.5	18 x 1.5	12 x 1.5
803616	M16 x 1.5	15 x 1.5	22 x 1.5	16 x 1.5
803622	M22 x 1.5	15 x 1.5	22 x 1.5	16 x 1.5
803716	M16 x 1.5	16 x 2	22 x 1.5	16 x 1.5
803722	M22 x 1.5	16 x 2	22 x 1.5	16 x 1.5
803816	M16 x 1.5	18 x 2	22 x 1.5	16 x 1.5
803822	M22 x 1.5	18 x 2	22 x 1.5	16 x 1.5

808 SERIES FEMALE STUDS



Part Ref	Thread Size (F)	Tube Size (mm)
808212	F12 x 1.5	6 x 1
808216	F16 x 1.5	6 x 1
808222	F22 x 1.5	6 x 1
808312	F12 x 1.5	8 x 1
808316	F16 x 1.5	8 x 1
808322	F22 x 1.5	8 x 1
808412	F12 x 1.5	10 x 1.25
808416	F16 x 1.5	10 x 1.25
808422	F22 x 1.5	10 x 1.25
808512	F12 x 1.5	12 x 1.5
808516	F16 x 1.5	12 x 1.5
808522	F22 x 1.5	12 x 1.5
808616	F16 x 1.5	15 x 1.5
808622	F22 x 1.5	15 x 1.5
808716	F16 x 1.5	16 x 2
808722	F22 x 1.5	16 x 2
808816	F16 x 1.5	18 x 2
808822	F22 x 1.5	18 x 2

PLEASE NOTE

For the male / female Bulk Heads please see page 28

* Female Studs are 2 piece*

6 SERIES SWIVEL SUB COMPONENTS

615 SERIES (SWIVEL ELBOWS)

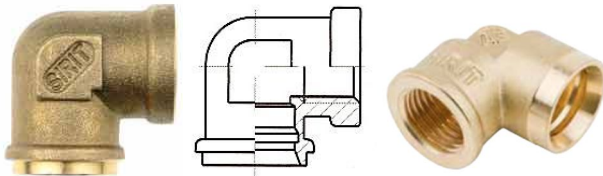

Part Ref	Thread Size (mm)	Tipo Size
615300	12 x 1.5	A
615500	16 x 1.5	B

645 SERIES (SWIVEL 45° ELBOWS)

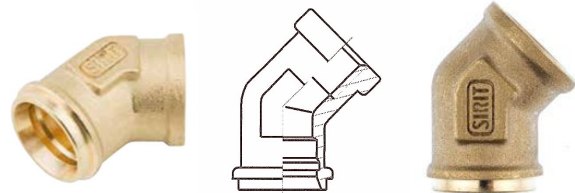

Part Ref	Thread Size (mm)	Tipo Size
645500	16 x 1.5	B

625 SERIES (STUD RUN TEE)

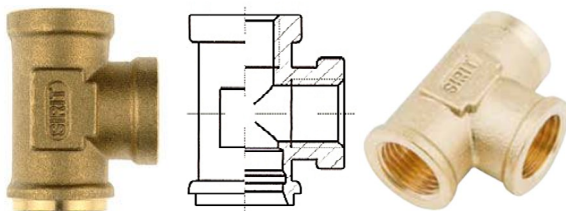

Part Ref	Thread Size (mm)	Tipo Size
625300	12 x 1.5	A
625500	16 x 1.5	B

646 SERIES (SWIVEL CROSS)

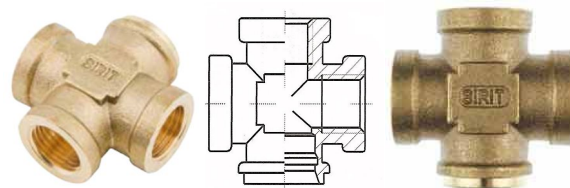

Part Ref	Thread Size (mm)	Tipo Size
646500	16 x 1.5	B

635 SERIES (STUD TEES)

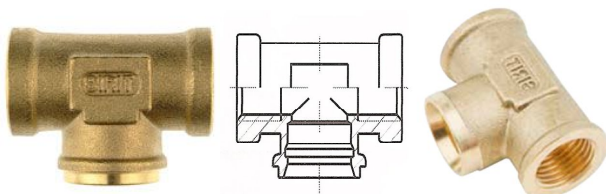

Part Ref	Thread Size (mm)	Tipo Size
635300	12 X 1.5	A
635500	16 x 1.5	B

647 SERIES (Y CORNER TEE)

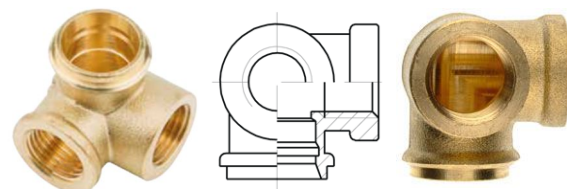

Part Ref	Thread Size (mm)	Tipo Size
647500	16 x 1.5	B

Swivel studs and the sub components must be paired
A+A / B+B

**PLEASE
NOTE:**

6 SERIES SWIVEL SUB COMPONENTS

648 SERIES (Y CORNER CROSS)

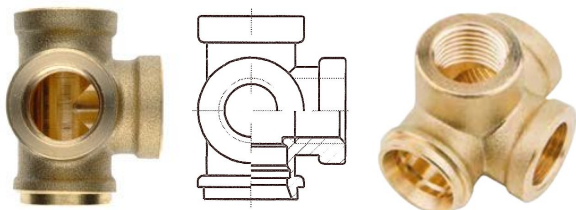

Part Ref	Thread Size (mm)	Tipo Size
648500	16 x 1.5	B

649 SERIES (CORNER CROSS)

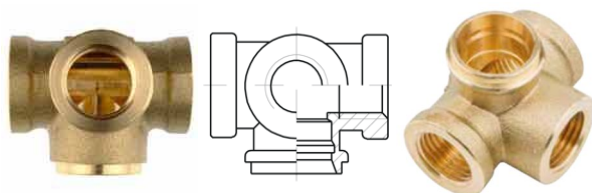

Part Ref	Thread Size (mm)	Tipo Size
649500	16 x 1.5	B

651 SERIES (SWIVEL F FITTING)

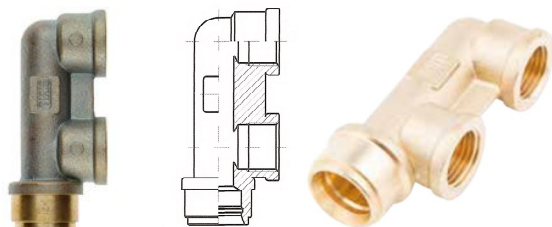

Part Ref	Thread Size (mm)	Tipo Size
651500	16 x 1.5	B

TIPO

660 SERIES (SWIVEL STUDS)

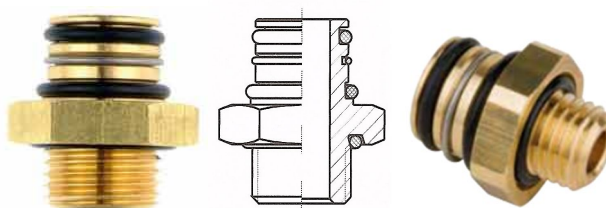

Part Ref	Thread Size	Tipo Size
----------	-------------	-----------

660302	1/8"	A
660304	1/4"	A
660310	M10 x 1	A
660312	M12 x 1.5	A
660314	M14 x 1.5	A
660316	M16 x 1.5	A
660322	M22 x 1.5	A

660502	1/8"	B
660504	1/4" Tapered	B
660504G	1/4" Parallel	B
660512	M12 x 1.5	B
660514	M14 x 1.5	B
660516	M16 x 1.5	B
660522	M22 x 1.5	B
660526	M26 x 1.5	B

Swivel studs and the sub components must be paired



A+A / B+B

815 SERIES SWIVEL ELBOWS



PART COMPLETE WITH THE SUB TIPO

Part Ref	Thread Size	Tube (mm)
815202	1/8"	6 x 1
815204	1/4"	6 x 1
815210	M10 x 1	6 x 1
815212	M12 x 1.5	6 x 1
815214	M14 x 1.5	6 x 1
815216	M16 x 1.5	6 x 1
815222	M22 x 1.5	6 x 1

Part Ref	Thread Size	Tube (mm)
815414	M14 x 1.5	10 x 1.25
815416	M16 x 1.5	10 x 1.25
815422	M22 x 1.5	10 x 1.25
815512	M12 x 1.5	12 x 1.5
815514	M14 x 1.5	12 x 1.5
815516	M16 x 1.5	12 x 1.5
815522	M22 x 1.5	12 x 1.5

PARTS WITHOUT THE SUB TIPO

Part Ref	Tipo	Tube (mm)
815200	B	6 x 1
815300	B	8 x 1
815400	B	10 x 1.25
815500	B	12 x 1.5
815600	B	15 x 1.5
815700	B	16 x 2
815800	B	18 x 2

815302	1/8"	8 x 1
815304	1/4"	8 x 1
815310	M10 x 1	8 x 1
815312	M12 x 1.5	8 x 1
815314	M14 x 1.5	8 x 1
815316	M16 x 1.5	8 x 1
815322	M22 x 1.5	8 x 1

815616	M16 x 1.5	15 x 1.5
815622	M22 x 1.5	15 x 1.5
815716	M16 x 1.5	16 x 2
815722	M22 x 1.5	16 x 2

815816	M16 x 1.5	18 x 2
815822	M22 x 1.5	18 x 2

815410	M10 x 1	10 x 1.25
815412	M12 x 1.5	10 x 1.25

825 SERIES SWIVEL STUD RUN TEES



PART COMPLETE WITH THE SUB TIPO

Part Ref	Thread Size	Tube (mm)
825202	1/8"	6 x 1
825204	1/4"	6 x 1
825210	M10 x 1	6 x 1
825212	M12 x 1.5	6 x 1
825214	M14 x 1.5	6 x 1
825216	M16 x 1.5	6 x 1
825222	M22 x 1.5	6 x 1

Part Ref	Thread Size	Tube (mm)
825414	M14 x 1.5	10 x 1.25
825416	M16 x 1.5	10 x 1.25
825422	M22 x 1.5	10 x 1.25
825512	M12 x 1.5	12 x 1.5
825514	M14 x 1.5	12 x 1.5
825516	M16 x 1.5	12 x 1.5
825522	M22 x 1.5	12 x 1.5

PARTS WITHOUT THE SUB TIPO

Part Ref	Tipo	Tube (mm)
825200	B	6 x 1
825300	B	8 x 1
825400	B	10 x 1.25
825500	B	12 x 1.5
825600	B	15 x 1.5
825700	B	16 x 2
825800	B	18 x 2

825302	1/8"	8 x 1
825304	1/4"	8 x 1
825310	M10 x 1	8 x 1
825312	M12 x 1.5	8 x 1
825314	M14 x 1.5	8 x 1
825316	M16 x 1.5	8 x 1
825322	M22 x 1.5	8 x 1

825616	M16 x 1.5	15 x 1.5
825622	M22 x 1.5	15 x 1.5
825716	M16 x 1.5	16 x 2
825722	M22 x 1.5	16 x 2

825816	M16 x 1.5	18 x 2
825822	M22 x 1.5	18 x 2

825410	M10 x 1	10 x 1.25
825412	M12 x 1.5	10 x 1.25

All parts available in 9mm & 11 mm

835 SERIES SWIVEL STUD TEES



PART COMPLETE WITH THE SUB TIPO

Part Ref	Thread Size	Tube (mm)
835210	M10 x 1	6 x 1
835212	M12 x 1.5	6 x 1
835214	M14 x 1.5	6 x 1
835216	M16 x 1.5	6 x 1
835222	M22 x 1.5	6 x 1

Part Ref	Thread Size	Tube (mm)
835512	M12 x 1.5	12 x 1.5
835514	M14 x 1.5	12 x 1.5
835516	M16 x 1.5	12 x 1.5
835522	M22 x 1.5	12 x 1.5

PARTS WITHOUT THE SUB TIPO

Part Ref	Tipo	Tube (mm)
835200	B	6 x 1
835300	B	8 x 1
835400	B	10 x 1.25
835500	B	12 x 1.5
835600	B	15 x 1.5
835700	B	16 x 2
835800	B	18 x 2

835310	M10 x 1	8 x 1
835312	M12 x 1.5	8 x 1
835314	M14 x 1.5	8 x 1
835316	M16 x 1.5	8 x 1
835322	M22 x 1.5	8 x 1

835612	M12 x 1.5	15 x 1.5
835614	M14 x 1.5	15 x 1.5
835616	M16 x 1.5	15 x 1.5
835622	M22 x 1.5	15 x 1.5

835716	M16 x 1.5	16 x 2
835722	M22 x 1.5	16 x 2

835816	M16 x 1.5	18 x 2
835822	M22 x 1.5	18 x 2

835412	M12 x 1.5	10 x 1.25
835414	M14 x 1.5	10 x 1.25
835416	M16 x 1.5	10 x 1.25
835422	M22 x 1.5	10 x 1.25

845 SERIES SWIVEL 45° ELBOWS



PART COMPLETE WITH THE SUB TIPO

Part Ref	Thread Size	Tube (mm)
845210	M10 x 1	6 x 1
845212	M12 x 1.5	6 x 1
845214	M14 x 1.5	6 x 1
845216	M16 x 1.5	6 x 1
845222	M22 x 1.5	6 x 1

Part Ref	Thread Size	Tube (mm)
845512	M12 x 1.5	12 x 1.5
845514	M14 x 1.5	12 x 1.5
845516	M16 x 1.5	12 x 1.5
845522	M22 x 1.5	12 x 1.5

PARTS WITHOUT THE SUB TIPO

Part Ref	Tipo	Tube (mm)
845200	B	6 x 1
845300	B	8 x 1
845400	B	10 x 1.25
845500	B	12 x 1.5
845600	B	15 x 1.5
845700	B	16 x 2
845800	B	18 x 2

845310	M10 x 1	8 x 1
845312	M12 x 1.5	8 x 1
845314	M14 x 1.5	8 x 1
845316	M16 x 1.5	8 x 1
845322	M22 x 1.5	8 x 1

845612	M12 x 1.5	15 x 1.5
845614	M14 x 1.5	15 x 1.5
845616	M16 x 1.5	15 x 1.5
845622	M22 x 1.5	15 x 1.5

845716	M16 x 1.5	16 x 2
845722	M22 x 1.5	16 x 2

845816	M16 x 1.5	18 x 2
845822	M22 x 1.5	18 x 2

845412	M12 x 1.5	10 x 1.25
845414	M14 x 1.5	10 x 1.25
845416	M16 x 1.5	10 x 1.25
845422	M22 x 1.5	10 x 1.25

All parts available in 9mm & 11 mm and all in Imperial threads

846 SERIES SWIVEL STUD CROSS



PART COMPLETE WITH THE SUB TIPO

Part Ref	Thread Size	Tube (mm)
846210	M10 x 1	6 x 1
846212	M12 x 1.5	6 x 1
846214	M14 x 1.5	6 x 1
846216	M16 x 1.5	6 x 1
846222	M22 x 1.5	6 x 1

Part Ref	Thread Size	Tube (mm)
846512	M12 x 1.5	12 x 1.5
846514	M14 x 1.5	12 x 1.5
846516	M16 x 1.5	12 x 1.5
846522	M22 x 1.5	12 x 1.5

PARTS WITHOUT THE SUB TIPO

Part Ref	Tipo	Tube (mm)
846200	B	6 x 1
846300	B	8 x 1
846400	B	10 x 1.25
846500	B	12 x 1.5
846600	B	15 x 1.5
846700	B	16 x 2
846800	B	18 x 2

846310	M10 x 1	8 x 1
846312	M12 x 1.5	8 x 1
846314	M14 x 1.5	8 x 1
846316	M16 x 1.5	8 x 1
846322	M22 x 1.5	8 x 1

846612	M12 x 1.5	15 x 1.5
846614	M14 x 1.5	15 x 1.5
846616	M16 x 1.5	15 x 1.5
846622	M22 x 1.5	15 x 1.5

846716	M16 x 1.5	16 x 2
846722	M22 x 1.5	16 x 2

846816	M16 x 1.5	18 x 2
846822	M22 x 1.5	18 x 2

846412	M12 x 1.5	10 x 1.25
846414	M14 x 1.5	10 x 1.25
846416	M16 x 1.5	10 x 1.25
846422	M22 x 1.5	10 x 1.25

847 SERIES SWIVEL 'Y' CORNER ELBOWS



PART COMPLETE WITH THE SUB TIPO

Part Ref	Thread Size	Tube (mm)
847210	M10 x 1	6 x 1
847212	M12 x 1.5	6 x 1
847214	M14 x 1.5	6 x 1
847216	M16 x 1.5	6 x 1
847222	M22 x 1.5	6 x 1

Part Ref	Thread Size	Tube (mm)
847512	M12 x 1.5	12 x 1.5
847514	M14 x 1.5	12 x 1.5
847516	M16 x 1.5	12 x 1.5
847522	M22 x 1.5	12 x 1.5

PARTS WITHOUT THE SUB TIPO

Part Ref	Tipo	Tube (mm)
847200	B	6 x 1
847300	B	8 x 1
847400	B	10 x 1.25
847500	B	12 x 1.5
847600	B	15 x 1.5
847700	B	16 x 2
847800	B	18 x 2

847310	M10 x 1	8 x 1
847312	M12 x 1.5	8 x 1
847314	M14 x 1.5	8 x 1
847316	M16 x 1.5	8 x 1
847322	M22 x 1.5	8 x 1

847612	M12 x 1.5	15 x 1.5
847614	M14 x 1.5	15 x 1.5
847616	M16 x 1.5	15 x 1.5
847622	M22 x 1.5	15 x 1.5

847716	M16 x 1.5	16 x 2
847722	M22 x 1.5	16 x 2

847816	M16 x 1.5	18 x 2
847822	M22 x 1.5	18 x 2

847412	M12 x 1.5	10 x 1.25
847414	M14 x 1.5	10 x 1.25
847416	M16 x 1.5	10 x 1.25
847422	M22 x 1.5	10 x 1.25

All parts available in 9mm & 11 mm and all in Imperial threads

848 SERIES SWIVEL CORNER CROSS



PART COMPLETE WITH THE SUB TIPO

Part Ref	Thread Size	Tube (mm)
848210	M10 x 1	6 x 1
848212	M12 x 1.5	6 x 1
848214	M14 x 1.5	6 x 1
848216	M16 x 1.5	6 x 1
848222	M22 x 1.5	6 x 1

Part Ref	Thread Size	Tube (mm)
848512	M12 x 1.5	12 x 1.5
848514	M14 x 1.5	12 x 1.5
848516	M16 x 1.5	12 x 1.5
848522	M22 x 1.5	12 x 1.5

PARTS WITHOUT THE SUB TIPO

Part Ref	Tipo	Tube (mm)
848200	B	6 x 1
848300	B	8 x 1
848400	B	10 x 1.25
848500	B	12 x 1.5
848600	B	15 x 1.5
848700	B	16 x 2
848800	B	18 x 2

848310	M10 x 1	8 x 1
848312	M12 x 1.5	8 x 1
848314	M14 x 1.5	8 x 1
848316	M16 x 1.5	8 x 1
848322	M22 x 1.5	8 x 1

848612	M12 x 1.5	15 x 1.5
848614	M14 x 1.5	15 x 1.5
848616	M16 x 1.5	15 x 1.5
848622	M22 x 1.5	15 x 1.5

848716	M16 x 1.5	16 x 2
848722	M22 x 1.5	16 x 2

848816	M16 x 1.5	18 x 2
848822	M22 x 1.5	18 x 2

848412	M12 x 1.5	10 x 1.25
848414	M14 x 1.5	10 x 1.25
848416	M16 x 1.5	10 x 1.25
848422	M22 x 1.5	10 x 1.25

849 SERIES SWIVEL SIDE TEES



PART COMPLETE WITH THE SUB TIPO

Part Ref	Thread Size	Tube (mm)
849210	M10 x 1	6 x 1
849212	M12 x 1.5	6 x 1
849214	M14 x 1.5	6 x 1
849216	M16 x 1.5	6 x 1
849222	M22 x 1.5	6 x 1

Part Ref	Thread Size	Tube (mm)
849512	M12 x 1.5	12 x 1.5
849514	M14 x 1.5	12 x 1.5
849516	M16 x 1.5	12 x 1.5
849522	M22 x 1.5	12 x 1.5

PARTS WITHOUT THE SUB TIPO

Part Ref	Tipo	Tube (mm)
849200	B	6 x 1
849300	B	8 x 1
849400	B	10 x 1.25
849500	B	12 x 1.5
849600	B	15 x 1.5
849700	B	16 x 2
849800	B	18 x 2

849310	M10 x 1	8 x 1
849312	M12 x 1.5	8 x 1
849314	M14 x 1.5	8 x 1
849316	M16 x 1.5	8 x 1
849322	M22 x 1.5	8 x 1

849612	M12 x 1.5	15 x 1.5
849614	M14 x 1.5	15 x 1.5
849616	M16 x 1.5	15 x 1.5
849622	M22 x 1.5	15 x 1.5

849716	M16 x 1.5	16 x 2
849722	M22 x 1.5	16 x 2

849816	M16 x 1.5	18 x 2
849822	M22 x 1.5	18 x 2

849412	M12 x 1.5	10 x 1.25
849414	M14 x 1.5	10 x 1.25
849416	M16 x 1.5	10 x 1.25
849422	M22 x 1.5	10 x 1.25

All parts available in 9mm & 11 mm and all in Imperial threads

851 SERIES SWIVEL 'F' ELBOW



PART COMPLETE WITH THE SUB TIPO

Part Ref	Thread Size	Tube (mm)
851210	M10 x 1	6 x 1
851212	M12 x 1.5	6 x 1
851214	M14 x 1.5	6 x 1
851216	M16 x 1.5	6 x 1
851222	M22 x 1.5	6 x 1

Part Ref	Thread Size	Tube (mm)
851512	M12 x 1.5	12 x 1.5
851514	M14 x 1.5	12 x 1.5
851516	M16 x 1.5	12 x 1.5
851522	M22 x 1.5	12 x 1.5

PARTS WITHOUT THE SUB TIPO

Part Ref	Tipo	Tube (mm)
851200	B	6 x 1
851300	B	8 x 1
851400	B	10 x 1.25
851500	B	12 x 1.5
851600	B	15 x 1.5
851700	B	16 x 2
851800	B	18 x 2

851310	M10 x 1	8 x 1
851312	M12 x 1.5	8 x 1
851314	M14 x 1.5	8 x 1
851316	M16 x 1.5	8 x 1
851322	M22 x 1.5	8 x 1

851612	M12 x 1.5	15 x 1.5
851614	M14 x 1.5	15 x 1.5
851616	M16 x 1.5	15 x 1.5
851622	M22 x 1.5	15 x 1.5

851716	M16 x 1.5	16 x 2
851722	M22 x 1.5	16 x 2

851816	M16 x 1.5	18 x 2
851822	M22 x 1.5	18 x 2

Screw the swivel Coupling into the thread ensuring the correct torque.
(Over-tightening can cause damage to both the fitting and the component).

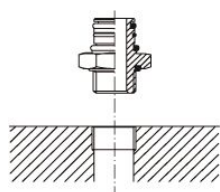

Then fit the component by means of push and twist.

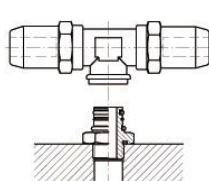

IMPORTANT:
Check the component is coupled correctly and securely.

Pull the component to ensure in this case.

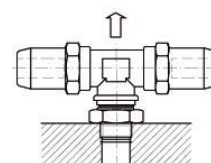

All swivel fittings are also available with
1/8" - 1/4" - M10 - M14 & M26 Threads

and to

9x1.5 mm - 11x1.5 mm - 10x1mm - 10x1.5mm Tube



Test point swivel tees also available upon request



SWIVEL THREADED ADAPTORS

715 SERIES SWIVEL ELBOWS



Part Ref	Male Thread	Female Thread
715302	1/8"	M12F x 1.5
715304	1/4"	M12F x 1.5
715310	M10 x 1	M12F x 1.5
715312	M12 x 1.5	M12F x 1.5
715314	M14 x 1.5	M12F x 1.5
715316	M16 x 1.5	M12F x 1.5
715322	M22 x 1.5	M12F x 1.5
715502	1/8"	M16F x 1.5
715504	1/4"	M16F x 1.5
715512	M12 x 1.5	M16F x 1.5
715514	M14 x 1.5	M16F x 1.5
715516	M16 x 1.5	M16F x 1.5
715522	M22 x 1.5	M16F x 1.5
715526	M26 x 1.5	M16F x 1.5

735 SERIES SWIVEL STUD TEES



Part Ref	Male Thread	Female Thread
735302	1/8"	M12F x 1.5
735304	1/4"	M12F x 1.5
735310	M10 x 1	M12F x 1.5
735312	M12 x 1.5	M12F x 1.5
735314	M14 x 1.5	M12F x 1.5
735316	M16 x 1.5	M12F x 1.5
735322	M22 x 1.5	M12F x 1.5
735502	1/8"	M16F x 1.5
735504	1/4"	M16F x 1.5
735512	M12 x 1.5	M16F x 1.5
735514	M14 x 1.5	M16F x 1.5
735516	M16 x 1.5	M16F x 1.5
735522	M22 x 1.5	M16F x 1.5
735526	M26 x 1.5	M16F x 1.5

725 SERIES SWIVEL STUD RUN TEES



Part Ref	Male Thread	Female Thread
725302	1/8"	M12F x 1.5
725304	1/4"	M12F x 1.5
725310	M10 x 1	M12F x 1.5
725312	M12 x 1.5	M12F x 1.5
725314	M14 x 1.5	M12F x 1.5
725316	M16 x 1.5	M12F x 1.5
725322	M22 x 1.5	M12F x 1.5
725502	1/8"	M16F x 1.5
725504	1/4"	M16F x 1.5
725512	M12 x 1.5	M16F x 1.5
725514	M14 x 1.5	M16F x 1.5
725516	M16 x 1.5	M16F x 1.5
725522	M22 x 1.5	M16F x 1.5
725526	M26 x 1.5	M16F x 1.5

745 SERIES SWIVEL 45 DEGREE ELBOWS



Part Ref	Male Thread	Female Thread
745302	1/8"	M12F x 1.5
745304	1/4"	M12F x 1.5
745310	M10 x 1	M12F x 1.5
745312	M12 x 1.5	M12F x 1.5
745314	M14 x 1.5	M12F x 1.5
745316	M16 x 1.5	M12F x 1.5
745322	M22 x 1.5	M12F x 1.5
745502	1/8"	M16F x 1.5
745504	1/4"	M16F x 1.5
745512	M12 x 1.5	M16F x 1.5
745514	M14 x 1.5	M16F x 1.5
745516	M16 x 1.5	M16F x 1.5
745522	M22 x 1.5	M16F x 1.5
745526	M26 x 1.5	M16F x 1.5

SWIVEL THREADED ADAPTORS

Part Ref	Male Thread	Female Thread
746502	1/8"	M16F x 1.5
746504	1/4"	M16F x 1.5
746510	M10 x 1	M16F x 1.5
746512	M12 x 1.5	M16F x 1.5
746514	M14 x 1.5	M16F x 1.5
746516	M16 x 1.5	M16F x 1.5
746522	M22 x 1.5	M16F x 1.5
746526	M26 x 1.5	M16F x 1.5

746 SERIES SWIVEL CROSS



747502	1/8"	M16F x 1.5
747504	1/4"	M16F x 1.5
745510	M10 x 1	M16F x 1.5
747512	M12 x 1.5	M16F x 1.5
747514	M14 x 1.5	M16F x 1.5
747516	M16 x 1.5	M16F x 1.5
747522	M22 x 1.5	M16F x 1.5
747526	M26 x 1.5	M16F x 1.5

747 SERIES SWIVEL 'Y' CORNER TEE



748502	1/8"	M16F x 1.5
748504	1/4"	M16F x 1.5
748510	M10 x 1	M16F x 1.5
748512	M12 x 1.5	M16F x 1.5
748514	M14 x 1.5	M16F x 1.5
748516	M16 x 1.5	M16F x 1.5
748522	M22 x 1.5	M16F x 1.5
748526	M26 x 1.5	M16F x 1.5

748 SERIES SWIVEL CORNER CROSS



749502	1/8"	M16F x 1.5
749510	M10 x 1	M16F x 1.5
749504	1/4"	M16F x 1.5
749512	M12 x 1.5	M16F x 1.5
749514	M14 x 1.5	M16F x 1.5
749516	M16 x 1.5	M16F x 1.5
749522	M22 x 1.5	M16F x 1.5
749526	M26 x 1.5	M16F x 1.5

749 SERIES SWIVEL SIDE CROSS



751502	1/8"	M16F x 1.5
751504	1/4"	M16F x 1.5
751510	M10 x 1	M16F x 1.5
751512	M12 x 1.5	M16F x 1.5
751514	M14 x 1.5	M16F x 1.5
751516	M16 x 1.5	M16F x 1.5
751522	M22 x 1.5	M16F x 1.5
751526	M26 x 1.5	M16F x 1.5

751 SERIES SWIVEL 'F' FITTING



FIXED ADAPTORS

710 SERIES FIXED 90° ELBOW



Part Ref	Male Thread	Female Thread
710310	M10 x 1	M12F x 1.5
710312	M12 x 1.5	M12F x 1.5
710314	M14 x 1.5	M12F x 1.5
710316	M16 x 1.5	M12F x 1.5
710322	M22 x 1.5	M12F x 1.5
710414	M14 x 1.5	M14 x 1.5
710512	M12 x 1.5	M16F x 1.5
710514	M14 x 1.5	M16F x 1.5
710516	M16 x 1.5	M16F x 1.5
710522	M22 x 1.5	M16F x 1.5
710716	M16 x 1.5	M22F x 1.5
710722	M22 x 1.5	M22F x 1.5

720 SERIES FIXED STUD RUN ELBOW



Part Ref	Male Thread	Female Thread
720310	M10 x 1	M12F x 1.5
720312	M12 x 1.5	M12F x 1.5
720316	M16 x 1.5	M12F x 1.5
720322	M22 x 1.5	M12F x 1.5
720512	M12 x 1.5	M16F x 1.5
720516	M16 x 1.5	M16F x 1.5
720522	M22 x 1.5	M16F x 1.5
720722	M22 x 1.5	M22F x 1.5

730 SERIES - FIXED TEE

Part	Male Thread	Female Thread
730310	M10 x 1	M12F x 1.5
730312	M12 x 1.5	M12F x 1.5
730316	M16 x 1.5	M12F x 1.5
730322	M22 x 1.5	M12F x 1.5
730512	M12 x 1.5	M16F x 1.5
730516	M16 x 1.5	M16F x 1.5
730522	M22 x 1.5	M16F x 1.5
730722	M22 x 1.5	M22F x 1.5



All fixed adaptors in any series come complete with a recessed Locknut and Sealing Ring

FIXED ADATORS

740 SERIES

45 DEGREE FIXED ELBOW



Part Ref	Male Thread	Female Thread
740516	M16 x 1.5	M16F x 1.5
740722	M22 x 1.5	M22F x 1.5

743 SERIES

90 DEGREE FIXED ELBOW



Part Ref	Male Thread	Female Thread
743516	M16 x 1.5	M16F x 1.5
743522	M22 x 1.5	M16F x 1.5

741 SERIES

FIXED STUD CROSS



All fixed adaptors in any series come complete with a recessed Locknut and Sealing Ring

Part Ref	Male Thread	Female Thread
741516	M16 x 1.5	M16F x 1.5
741522	M22 x 1.5	M16F x 1.5

FEMALE ADAPTORS

742 SERIES

FIXED "Y" ELBOW



Part Ref	Male Thread	Female Thread
742516	M16 x 1.5	M16F x 1.5
742522	M22 x 1.5	M16F x 1.5

750 SERIES

FEMALE THREADED BARREL

Part Ref	Female Thread
750200	M10F x 1
750300	M12F x 1.5
750400	M14F x 1.5
750500	M16F x 1.5
750700	M22F x 1.5

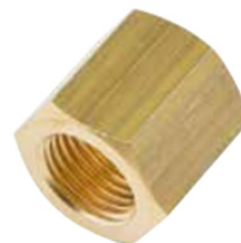

ADAPTORS

760 SERIES

90 DEGREE FEMALE ELBOW

Part Ref	Female Thread
760300	M12F x 1.5
760500	M16F x 1.5
760700	M22F x 1.5



753 SERIES

BULKHEAD ADAPTOR



Part Ref	M1	F1	F2
753300	M18 x 1.5	M12F x 1.5	M12F x 1.5
753500	M22 x 1.5	M16F x 1.5	M16F x 1.5
753700	M28 x 1.5	M22F x 1.5	M22F x 1.5
753302	M18 x 1.5	M12F x 1.5	1/8"
753504	M22 x 1.5	M16F x 1.5	1/4"

If lock nut is not required on the adaptor series 753 it then becomes an 653

753300 to 653300

770 SERIES

FEMALE TEE

Part	Female Thread
770300	M12F x 1.5
770500	M16F x 1.5
770700	M22F x 1.5



Part	Female Thread
770500BT	M16F x 1.5

BRACKETED FEMALE TEE



703 SERIES

BULKHEAD COUPLING



Part Ref	M1	M2	F1
703216	M16 x 1.5	M16 x 1.5	M10F x 1
703222	M22 x 1.5	M16 x 1.5	M10F x 1
703312	M12 x 1.5	M18 x 1.5	M12F x 1.5
703316	M16 x 1.5	M18 x 1.5	M12F x 1.5
703322	M22 x 1.5	M18 x 1.5	M12F x 1.5
703512	M12 x 1.5	M22 x 1.5	M16F x 1.5
703516	M16 x 1.5	M22 x 1.5	M16F x 1.5
703522	M22 x 1.5	M22 x 1.5	M16F x 1.5
703526	M26 x 1.5	M22 x 1.5	M16F x 1.5
703722	M22 x 1.5	M28 x 1.5	M22F x 1.5

If lock nut is not required on the adaptor series 703 it then becomes a 603

703516 to 603516

780 SERIES

FEMALE CROSS

Part	Female Thread
780300	M12F x 1.5
780500	M16F x 1.5



950 SERIES

BRACKETED 'Y'

Part	Female Thread
950500BT	M16F x 1.5



FITTING ADAPTORS

763 SERIES

**MALE/FEMALE 90 DEGREE
BULKHEAD ELBOW**



Part Ref	Male Thread	Female Thread
763300	M18 x 1.5	M12F x 1.5
763500	M22 x 1.5	M16F x 1.5
763700	M22 x 1.5	M22F x 1.5

If lock nut is not required on the adaptor series 763 it then becomes a 663 (763500 to 663500)

853 SERIES

**EQUAL BULKHEAD
COUPLING**



Part Ref	Tube Size (mm)	Female Thread
853200	6 x 1	M12F x 1.5
853300	8 x 1	M12F x 1.5
853400	10 x 1.25	M12F x 1.5
853400/5	10 x 1.5	M12F x 1.5
853500	12 x 1.5	M16F x 1.5
853600	15 x 1.5	M16F x 1.5
853700	16 x 2	M16F x 1.5
853800	18 x 2	M16F x 1.5

863 SERIES

**EQUAL 90 DEGREE
BULKHEAD ELBOW**



Part Ref	Tube Size (mm)	Female Thread
863200	6 x 1	M12F x 1.5
863300	8 x 1	M12F x 1.5
863400	10 x 1.25	M12F x 1.5
863400/5	10 x 1.5	M12F x 1.5
863500	12 x 1.5	M16F x 1.5
863600	15 x 1.5	M16F x 1.5
863700	16 x 2	M16F x 1.5
863800	18 x 2	M16F x 1.5

MALE BULKHEAD ELBOW



Part Ref	Tube Size (mm)	Thread
863222	6 x 1	M22 x 1.5
863322	8 x 1	M22 x 1.5
863422	10 x 1.25	M22 x 1.5
863522	12 x 1.5	M22 x 1.5
863622	15 x 1.5	M22 x 1.5
863722	16 x 2	M22 x 1.5
863822	18 x 2	M22 x 1.5

HOSETAIL ELBOW



Part Ref	Hose ID	Thread
910912/6	3/8" & 11mm	M12 x 1.5
910916/6	3/8" & 11mm	M16 x 1.5
910922/6	3/8" & 11mm	M22 x 1.5
910912	1/2" & 13mm	M12 x 1.5
910916	1/2" & 13mm	M16 x 1.5
910922	1/2" & 13mm	M22 x 1.5

MALE - MALE ELBOW

Part	Thread
MME22Z	M22 x 1.5



MALE LOCKING TEE

Part	Thread
MLT16Z	M16 x 1.5
MLT22Z	M22 x 1.5



EQUAL TUBE CONNECTORS

850 SERIES - STRAIGHT EQUAL JOINER

Part Ref	Tube Size (mm)
----------	----------------

850200	6 x 1
850300	8 x 1
850900	9 x 1.5
850400	10 x 1.25
850110	11 x 1.5



Part Ref	Tube Size (mm)
----------	----------------

850500	12 x 1.5
850600	15 x 1.5
850700	16 x 2
850800	18 x 2

860 SERIES



870 SERIES



880 SERIES



Part Ref	Tube Size (mm)	Female Thread
----------	----------------	---------------

90 DEGREE EQUAL ELBOW JOINER

860200	6 x 1	M12F x 1.5
860300	8 x 1	M12F x 1.5
860900	9 x 1.5	M12F x 1.5
860400	10 x 1.25	M12F x 1.5
860110	11 x 1.5	M12F x 1.5
860500	12 x 1.5	M16F x 1.5
860600	15 x 1.5	M16F x 1.5
860700	16 x 2	M16F x 1.5
860800	18 x 2	M16F x 1.5

Part Ref	Tube Size (mm)	Female Thread
----------	----------------	---------------

TEE EQUAL JOINER

870200	6 x 1	M12F x 1.5
870300	8 x 1	M12F x 1.5
870900	9 x 1.5	M12F x 1.5
870400	10 x 1.25	M12F x 1.5
870110	11 x 1.5	M12F x 1.5
870500	12 x 1.5	M16F x 1.5
870600	15 x 1.5	M16F x 1.5
870700	16 x 2	M16F x 1.5
870800	18 x 2	M16F x 1.5

Part Ref	Tube Size (mm)	Female Thread
----------	----------------	---------------

CROSS EQUAL JOINER

880200	6 x 1	M12F x 1.5
880300	8 x 1	M12F x 1.5
880900	9 x 1.5	M12F x 1.5
880400	10 x 1.25	M12F x 1.5
880110	11 x 1.5	M12F x 1.5
880500	12 x 1.5	M16F x 1.5
880600	15 x 1.5	M16F x 1.5
880700	16 x 2	M16F x 1.5
880800	18 x 2	M16F x 1.5

Please Note!

All studs can be unscrewed if you require to make an unequal connector
(Apart from the Straights)

BLANKING PLUGS

BRASS WITH SEALS



Part	Thread
BP12B	M12 x 1.5
BP16B	M16 x 1.5
BP22B	M22 x 1.5

MALE - FEMALE ADAPTORS

BRASS WITH SEALS



Part	Male Thread	Female Thread
MFA2212B	M22 x 1.5	F12 x 1.5
MFA2216B	M22 x 1.5	F16 x 1.5

RECESSED LOCK NUTS & SEALS

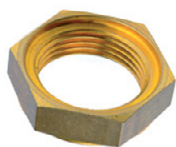

Part Ref	Size
----------	------

LOCKING NUTS

692010	M10 x 1
692012	M12 x 1.5
692014	M14 x 1.5
692016	M16 x 1.5
692022	M22 x 1.5

Part Ref	Size
----------	------

SEALS

693010	10 mm
693012	12 mm
693014	14 mm
693016	16 mm
693022	22 mm

Part Ref	Size
----------	------

SEALS & NUT PACK (1 each)

692010/693	10 mm
623012/693	12 mm
692014/693	14 mm
692016/693	16 mm
692022/693	22 mm

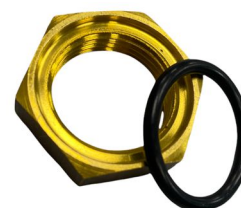

Supplied in packs
of 1 each

ASSORTED BOXES:

All boxes come clearly labelled to identify parts and sizes

ASSORTED MALE STUDS - Part ref: 800AB



Part Ref	Size	Qty	Part Ref	Size	Qty
800312	M12 x 8mm	2	800516	M16 x 12mm	2
800316	M16 x 8mm	2	800522	M22 x 12mm	2
800416	M16 x 10mm	2	800622	M22 x 15mm	1
800422	M22 x 10mm	2	800822	M22 x 18mm	1

ASSORTED MALE ELBOWS - Part Ref: 810AB



Part Ref	Size	Qty	Part Ref	Size	Qty
810312	M12 x 8mm	2	810422	M22 x 10mm	1
810316	M16 x 8mm	2	810516	M16 x 12mm	1
810322	M22 x 8mm	2	810522	M22 x 12mm	1
810412	M12 x 10mm	2	810622	M22 x 15mm	1
810416	M16 x 10mm	2	810822	M22 x 18mm	1

STRAIGHT CONNECTORS - Part Ref: 850AB



Part Ref	Size	Qty	Part Ref	Size	Qty
850200	6 mm	2	850500	12 mm	2
850300	8 mm	2	850600	15 mm	2
850400	10 mm	2	850700	16 mm	2
			850800	18 mm	1

EXTRA PARTS AVAILABLE UPON REQUEST





SIRIT WORKSHOP & MOBILE REPAIR SERVICE KIT



SIRIT
AIR BRAKE FITTINGS

PART REF:

SIRITAB



For the unsuspected costly times when you either do not have the correct fittings to hand or you have to await delivery, which is normally a next day service.

Air brake Connections (TUV) Fitting Case will enable you to replace either individual fittings or a valve install/replacement.

Consisting of a variety of 26 fittings and a total of 120, and also giving you the opportunity to use the sub components to make the extra fittings you require.

For a Valve replacement, pre-fit new fittings into the braking valve/valves, remove old unit/valve and either remove the tubing one by one and replace the new tubing one by one (note: the tubing must be cut cleanly and squarely), alternatively clearly label each tube. Remove and refit unit/valve and simply cut away the tube squarely, push and twist the new tubing into position (note: a pull backward on the tubing is recommend to ensure full lock has been achieved).

All fittings supplied in the Case can be used on any braking application.

A clearly labelled list of contents is applied to each Service Kit to allow easy re-ordering.

Our Service Kit is designed for repair and servicing and therefore will suit most requirements for today's braking systems.

All Fittings are TUV approved for braking applications.



SWIVEL STUD M12 X 4	MALE STUD M16 X 6mm X 4	
SWIVEL STUD M16 X 6	MALE STUD M12 X 8mm X 8	FEMALE ADAPTOR M16F X 8
SWIVEL STUD M22 X 4	MALE STUD M16 X 8mm X 6	BLANKING PLUG M12 X 4
SWIVEL ELBOW M16F X 4	MALE STUD M16 X 10mm X 6	BLANKING PLUG M16 X 4
45° SWIVEL ELBOW M16F X 4	MALE STUD M22 X 10mm X 6	BLANKING PLUG M22 X 4
'F' FITTING M16F X 2	MALE STUD M16 X 12mm X 6	TEST POINT M16 X 4
SWIVEL SIDE TEE M16F X 4	MALE STUD M22 X 12mm X 6	TEST POINT M22 X 4
SWIVEL BRANCH TEE M16F X 4	MALE STUD M22 X 15mm X 4	BULKHEAD M16 X M22 X M16F X 3
	MALE STUD M22 X 16mm X 4	BULKHEAD M22 X M22 X M16F X 3
	MALE STUD M22 X 18mm X 4	

SECTION

2



COMPRESSION RANGE NUT & OLIVE



COMPRESSION RANGE - NUT & OLIVE

BULKHEAD ADAPTORS



Part Ref	Thread Size A	Thread Size B
BA1212Z	M12 x 1.5	M12 x 1.5
BA1414Z	M14 x 1.5	M14 x 1.5
BA1422Z	M14 x 1.5	M22 x 1.5
BA1616Z	M16 x 1.5	M16 x 1.5
BA1618Z	M16 x 1.5	M18 x 1.5
BA1622Z	M16 x 1.5	M22 x 1.5
BA1818Z	M18 x 1.5	M18 x 1.5
BA2222Z	M22 x 1.5	M22 x 1.5
BA2216Z	M22 x 1.5	M16 X 1.5
BA2218Z	M22 x 1.5	M18 x 1.5
BA2250Z	M22 x 1.5	1/2"

Bulkhead adaptors as above C/W olive cut out (Tube Ended)

Part Ref	Thread	Tube OD
BAT12	M12	6 mm
BAT14	M14	8 mm
BAT16	M16	10 mm
BAT18	M18	12 mm
BAT22	M22	15 mm
BAT22/16	M22	16 mm
BAT2626	M26	18 mm

BLANKING PLUGS



Add a 'T' to end of Part Ref if required with seals

Part Ref	Thread Size
BP10	M10 x 1
BP12	M12 x 1.5
BP14	M14 x 1.5
BP16	M16 x 1.5
BP18	M18 x 1.5
BP22	M22 x 1.5
BP26	M26 x 1.5

ALLEN KEY



Part Ref	Thread
BP8AK	M8
BP10AK	M10
BP12AK	M12
BP14AK	M14
BP16AK	M16
BP18AK	M18
BP20AK	M20
BP22AK	M22
BP24AK	M24
BP26AK	M26

BRASS - C/W 'O' RING



Part Ref	Thread Size
BP12B	M12 x 1.5
BP16B	M16 x 1.5
BP22B	M22 x 1.5

BLANKING CAPS



Part Ref	Tube OD
BPC6	6 mm
BPC8	8 mm
BPC10	10 mm
BPC12	12 mm

BRANCH STEM TEE



Part Ref	Tube OD	Stem OD
BST6Z	6 mm	6 mm
BST8Z	8 mm	8 mm
BST10Z	10 mm	10 mm
BST12Z	12 mm	12 mm
BST15Z	15 mm	15 mm

BULKHEAD STUD COUPLINGS



Part Ref	Thread	Tube OD
BSC86	1/2"	3/8"
BSC88	1/2"	1/2"

COMPRESSION RANGE NUT & OLIVE

EQUAL BULKHEAD



Part Ref	Tube OD
EBC6Z	6 mm
EBC8Z	8 mm
EBC10Z	10 mm
EBC12Z	12 mm
EBC15Z	15 mm
EBC16Z	16 mm
EBC18Z	18 mm

EQUAL ELBOW



Part Ref	Tube OD
EE6Z	6 mm
EE8Z	8 mm
EE10Z	10 mm
EE12Z	12 mm
EE15Z	15 mm
EE16Z	16 mm
EE18Z	18 mm

EQUAL BULKHEAD ELBOW



Part Ref	Tube OD
EBE6Z	6 mm
EBE8Z	8 mm
EBE10Z	10 mm
EBE12Z	12 mm
EBE15Z	15 mm
EBE16Z	16 mm
EBE18Z	18 mm

EQUAL TEE



Part Ref	Tube OD
ET6Z	6 mm
ET8Z	8 mm
ET10Z	10 mm
ET12Z	12 mm
ET15Z	15 mm
ET16Z	16 mm
ET18Z	18 mm

EQUAL CONNECTOR



Part Ref	Tube OD
EC4Z	4 mm
EC6Z	6 mm
EC8Z	8 mm
EC9Z	9 mm
EC10Z	10 mm
EC12Z	12 mm
EC15Z	15 mm
EC16Z	16 mm
EC18Z	18 mm

FEMALE ADAPTOR



Part Ref	Tread Size 1	Thread Size 2
FFA1612Z	M16 x 1.5	M12 x 1.5
FFA16Z	M16 x 1.5	M16 x 1.5
FFA22Z	M22 x 1.5	M22 x 1.5
FFA226Z	M22 x 1.5	3/8"
FFA227Z	M22 x 1.5	1/2"
FFA2216Z	M22 x 1.5	M16 x 1.5
FFA2218Z	M22 x 1.5	M18 x 1.5

COMPRESSION RANGE NUT & OLIVE

HOSETAIL STEMS



Part Ref	Tube OD	Tube ID
HS86Z	8 mm	3/8"
HS106Z	10 mm	3/8"
HS1011Z	10 mm	11 mm
HS1013Z	10 mm	13 mm
HS1211Z	12 mm	11 mm
HS1213Z	12 mm	13 mm

FIXED HOSETAILS (STEEL)

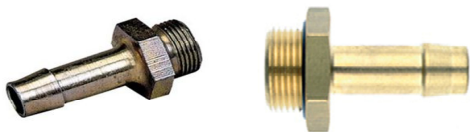

Part Ref	Thread Size	Tube ID
HTS166Z	M16 x 1.5	3/8"
HTS1611Z	M16 x 1.5	11 mm
HTS1613Z	M16 x 1.5	13 mm
HTS2211Z	M22 x 1.5	11 mm
HTS2213Z	M22 x 1.5	13 mm

FIXED HOSETAILS (BRASS)

Part Ref	Tread Size	Tube ID
HTS1613B	M16 x 1.5	13 mm
HTS2213B	M22 x 1.5	13 mm

LOCKING NUTS

STEEL

Part Ref	Tread Size
LN12Z	M12 x 1.5
LN14Z	M14 x 1.5
LN16Z	M16 x 1.5
LN18Z	M18 x 1.5
LN22Z	M22 x 1.5
LN26Z	M26 x 1.5

BRASS

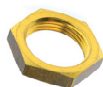

Part Ref	Tread Size
LN12B	M12 x 1.5
LN16B	M16 x 1.5
LN22B	M22 x 1.5

MALE FEMALE ADAPTORS

(BRASS)



Part Ref	Male Thread	Female Thread
MFA24B	1/8"	1/4"
MFA44B	1/4"	1/4"
MFA122B	M12 x 1.5	1/8"
MFA1610B	M16 x 1.5	M10 x 1
MFA1612B	M16 x 1.5	M12 x 1.5
MFA2212B	M22 x 1.5	M12 x 1.5
MFA2216B	M22 x 1.5	M16 x 1.5

MALE FEMALE ADAPTORS

(STEEL)



Part Ref	Male Tread	Female Thread
MFA24	1/8"	1/4"
MFA44	1/4"	1/4"
MFA46	1/4"	3/8"
MFA48	1/4"	1/2"
MFA412	1/4"	M12 x 1.5
MFA416	1/4"	M16 x 1.5
MFA422	1/4"	M22 x 1.5
MFA64	3/8"	1/4"
MFA616	3/8"	M16 x 1.5
MFA622	3/8"	M22 x 1.5
MFA716	1/2"	M16 x 1.5
MFA718	1/2"	M18 x 1.5
MFA722	1/2"	M22 x 1.5
MFA84	1/2"	1/4"
MFA86	1/2"	3/8"

COMPRESSION RANGE NUT & OLIVE

MALE - FEMALE ADAPTORS (STEEL)

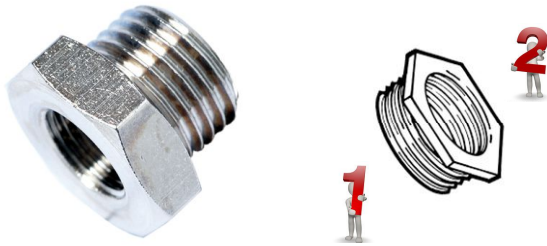

Part Ref	Thread Size 1	Thread Size 2
MFA122	M12 x 1.5	1/8"
MFA124	M12 x 1.5	1/4"
MFA1216	M12 x 1.5	M16 x 1.5
MFA1222	M12 x 1.5	M22 x 1.5
MFA1416	M14 x 1.5	M16 x 1.5
MFA1422	M14 x 1.5	M22 x 1.5
MFA164	M16 x 1.5	1/4"
MFA166	M16 x 1.5	3/8"
MFA167	M16 x 1.5	1/2"
MFA1610	M16 x 1.5	M10 x 1
MFA1612	M16 x 1.5	M12 x 1.5
MFA1616	M16 x 1.5	M16 x 1.5
MFA1622	M16 x 1.5	M22 x 1.5
MFA1822	M18 x 1.5	M22 x 1.5
MFA222	M22 x 1.5	1/8"
MFA224	M22 x 1.5	1/4"
MFA226	M22 x 1.5	3/8"
MFA227	M22 x 1.5	1/2"
MFA2212	M22 x 1.5	M12 x 1.5
MFA2214	M22 x 1.5	M14 x 1.5
MFA2216	M22 x 1.5	M16 x 1.5
MFA2218	M22 x 1.5	M18 x 1.5
MFA2622	M26 x 1.5	M22 x 1.5

MALE - MALE ADAPTORS (STEEL)



Part Ref	Thread Size	Thread Size
MMA212Z	1/8"	M12 x 1.5
MMA214Z	1/8"	M14 x 1.5
MMA216Z	1/8"	M16 x 1.5
MMA412Z	1/4"	M12 x 1.5
MMA414Z	1/4"	M14 x 1.5
MMA416Z	1/4"	M16 x 1.5
MMA418Z	1/4"	M18 x 1.5
MMA616Z	3/8"	M16 x 1.5
MMA618Z	3/8"	M18 x 1.5
MMA718Z	1/2"	M18 x 1.5
MMA822Z	1/2"	M22 x 1.5
MMA1012Z	M10 x 1	M12 x 1.5
MMA1014Z	M10 x 1	M14 x 1.5
MMA1016Z	M10 x 1	M16 x 1.5
MMA1212Z	M12 x 1.5	M12 x 1.5
MMA1218Z	M12 x 1.5	M18 x 1.5
MMA1222Z	M12 x 1.5	M22 x 1.5
MMA1412Z	M14 x 1.5	M12 x 1.5
MMA1414Z	M14 x 1.5	M14 x 1.5
MMA1418Z	M14 x 1.5	M18 x 1.5
MMA1612Z	M16 x 1.5	M12 x 1.5
MMA1614Z	M16 x 1.5	M14 x 1.5
MMA1616Z	M16 x 1.5	M16 x 1.5
MMA1618Z	M16 x 1.5	M18 x 1.5
MMA1622Z	M16 x 1.5	M22 x 1.5
MMA2212Z	M22 x 1.5	M12 x 1.5
MMA2214Z	M22 x 1.5	M14 x 1.5
MMA2216Z	M22 x 1.5	M16 x 1.5
MMA2218Z	M22 x 1.5	M18 x 1.5
MMA2222Z	M22 x 1.5	M22 x 1.5



If you require a Steel part complete with a Thrust & 'O' Ring on the male metric side please add a T to the end of the part:

EG: MFA2216 becomes MFA2216T

COMPRESSION RANGE NUT & OLIVE

ELBOW ADAPTORS



**MALE
FEMALE**

Part Ref	Thread Size	Female Thread
MFE1612	M16 x 1.5	M12 x 1.5
MFE1616	M16 x 1.5	M16 x 1.5
MFE1622	M16 x 1.5	M22 x 1.5
MFE2212	M22 x 1.5	M12 x 1.5
MFE2216	M22 x 1.5	M16 x 1.5
MFE2222	M22 x 1.5	M22 x 1.5

MALE - MALE



Part Ref	Thread Size	Thread Size
MME2222Z	M22 x 1.5	M22 x 1.5

MALE STUD COUPLINGS

Part Ref	Thread Size	Tube OD
MSC26Z	1/8"	6 mm
MSC28Z	1/8"	8 mm
MSC210Z	1/8"	10 mm
MSC46Z	1/4"	6 mm
MSC48Z	1/4"	8 mm
MSC410Z	1/4"	10 mm
MSC412Z	1/4"	12 mm
MSC610Z	3/8"	10 mm
MSC612Z	3/8"	12 mm
MSC812Z	1/2"	12 mm
MSC815Z	1/2"	15 mm
MSC106Z	M10 x 1	6 mm
MSC108Z	M10 x 1	8 mm
MSC1010Z	M10 x 1	10 mm
MSC126Z	M12 x 1.5	6 mm
MSC128Z	M12 x 1.5	8 mm
MSC1210Z	M12 x 1.5	10 mm
MSC1212Z	M12 x 1.5	12 mm
MSC146Z	M14 x 1.5	6 mm
MSC148Z	M14 x 1.5	8 mm
MSC1410Z	M14 x 1.5	10 mm



Part Ref	Thread Size	Tube OD
MSC1412Z	M14 x 1.5	12 mm
MSC1415Z	M14 x 1.5	15 mm
MSC166Z	M16 x 1.5	6 mm
MSC168Z	M16 x 1.5	8 mm
MSC1610Z	M16 x 1.5	10 mm
MSC1612Z	M16 x 1.5	12 mm
MSC1615Z	M16 x 1.5	15 mm
MSC1616Z	M16 x 1.5	16 mm
MSC226Z	M22 x 1.5	6 mm
MSC228Z	M22 x 1.5	8 mm
MSC2210Z	M22 x 1.5	10 mm
MSC2212Z	M22 x 1.5	12 mm
MSC2215Z	M22 x 1.5	15 mm
MSC2216Z	M22 x 1.5	16 mm
MSC2218Z	M22 x 1.5	18 mm



If you require a Part Number from the MSC range complete with a Thrust & 'O' Ring, add a T to the end of the Part Number: eg: MSC1610Z becomes MSC1610ZT

COMPRESSION RANGE NUT & OLIVE

STUD BULKHEAD COUPLINGS



Part Ref	Thread Size	Tube OD
SBC126Z	M12 x 1.5	6 mm
SBC168Z	M16 x 1.5	8 mm
SBC1610Z	M16 x 1.5	10 mm
SBC1612Z	M16 x 1.5	12 mm
SBC228Z	M22 x 1.5	8 mm
SBC2210Z	M22 x 1.5	10 mm
SBC2212Z	M22 x 1.5	12 mm
SBC2215Z	M22 x 1.5	15 mm
SBC2216Z	M22 x 1.5	16 mm
SBC2218Z	M22 x 1.5	18 mm

STUD ELBOWS



Part Ref	Thread Size	Tube OD
SE128Z	M12 x 1.5	8 mm
SE1210Z	M12 x 1.5	10 mm
SE148Z	M14 x 1.5	8 mm
SE1410Z	M14 x 1.5	10 mm
SE168Z	M16 x 1.5	8 mm
SE1610Z	M16 x 1.5	10 mm
SE1612Z	M16 x 1.5	12 mm
SE1615Z	M16 x 1.5	15 mm
SE228Z	M22 x 1.5	8 mm
SE2210Z	M22 x 1.5	10 mm
SE2212Z	M22 x 1.5	12 mm
SE2215Z	M22 x 1.5	15 mm
SE2216Z	M22 x 1.5	16 mm
SE2218Z	M22 x 1.5	18 mm

STEM ELBOWS



Part Ref	Tube OD	Stem OD
SE6Z	6 mm	6 mm
SE8Z	8 mm	8 mm
SE10Z	10 mm	10 mm
SE12Z	12 mm	12 mm
SE15Z	15 mm	15 mm
SE16Z	16 mm	16 mm
SE18Z	18 mm	18 mm

SIDE STEM TEE



Part Ref	Tube OD	Stem OD
SST6Z	6 mm	6 mm
SST8Z	8 mm	8 mm
SST10Z	10 mm	10 mm
SST12Z	12 mm	12 mm

STUD RUN TEES



Part Ref	Thread Size	Tube OD
SRT128Z	M12 x 1.5	8 mm
SRT1210Z	M12 x 1.5	10 mm
SRT168Z	M16 x 1.5	8 mm
SRT1610Z	M16 x 1.5	10 mm
SRT1612Z	M16 x 1.5	12 mm
SRT228Z	M22 x 1.5	8 mm
SRT2210Z	M22 x 1.5	10 mm
SRT2212Z	M22 x 1.5	12 mm

COMPRESSION RANGE NUT & OLIVE

STUD TEES



Part Ref	Tread Size	Tube OD
ST1010Z	M10 x 1.5	10 mm
ST126Z	M12 x 1.5	6 mm
ST128Z	M12 x 1.5	8 mm
ST1210Z	M12 x 1.5	10 mm
ST168Z	M16 x 1.5	8 mm
ST1610Z	M16 x 1.5	10 mm
ST1612Z	M16 x 1.5	12 mm
ST226Z	M22 x 1.5	6 mm
ST228Z	M22 x 1.5	8 mm
ST2210Z	M22 x 1.5	10 mm
ST2212Z	M22 x 1.5	12 mm
ST2215Z	M22 x 1.5	15 mm

PLEASE NOTE

THESE PARTS MAY NOT BE
ONE PIECE - PLEASE ENQUIRE FIRST

HOSETAILS

(SWIVEL FEMALE NUTS)



Part Ref	Thread	Hose ID
SWH106Z	M16 x 1.5	3/8"
SWH1011Z	M16 x 1.5	11 mm
SWH1013Z	M16 x 1.5	13 mm
SWH1211Z	M18 x 1.5	11 mm
SWH1213Z	M18 x 1.5	13 mm

MALE SWIVEL HOSETAILS



Part Ref	Male Thread	Tube ID
SWHT166Z	M16 x 1.5	3/8"
SWHT168Z	M16 x 1.5	1/2"
SWHT1613Z	M16 x 1.5	13 mm
SWHT228Z	M22 x 1.5	1/2"
SWHT2213Z	M22 x 1.5	13 mm

TEST POINT ADAPTORS

WING NUT

Part Ref	Tube ID
TPA1/W	3/16" - 5 mm
TPA2/W	1/4" - 7 mm
TPA3/W	3/8" - 10 mm



LONG STEM

Part Ref	Tube ID
TPA2L	1/4" - 7 mm
TPA3L	3/8" - 10 mm



**GAUGE HOSES CAN BE MADE TO MEASURE
AND GAUGES SOLD SEPERATELY - SECTION 18**



COMPRESSION RANGE NUT & OLIVE

FEMALE TEST POINTS - M16



Part Ref	Female Thread
TPF12	M12 x 1.5
TPF14	M14 x 1.5
TPF16	M16 x 1.5
TPF18	M18 x 1.5
TPF22	M22 x 1.5

MALE TEST POINTS - M16



Part Ref	Thread Size
TPM12T	M12 x 1.5
TPM14	M14 x 1.5
TPM16T	M16 x 1.5
TPM22T	M22 x 1.5
TPM25	1/4"

TILT / DRAIN TAP

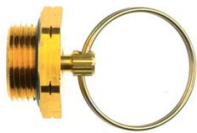

Part Ref	Thread Size
TT3T	M22 x 1.5
TT8	1/2"

PLASTIC TEST POINT CAP

Part Ref
TPC



TILT TAP C/W CABLE



Part Ref	Thread Size
----------	-------------

TTC3	M22 x 1.5	C/W 6ft CABLE
TT4	M22 x 1.5	NO CABLE

CABLE AND FERRULES



Part Ref	Thread Size
TF	FERRULE 1.5mm
DTC1	6ft Length

Part Numbers with a 'T' at the end comes complete with seals

TEE TEST POINT TEE



Part Ref	Tube OD
TTP8	8 mm
TTP10	10 mm
TTP12	12 mm
TTP15	15 mm

PLEASE NOTE

THESE PARTS MAY NOT BE ONE PIECE - PLEASE ENQUIRE FIRST

ASSEMBLY INSTRUCTIONS

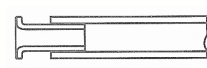
- 1: Firstly ensure the nylon tube is cut square.
 - 2: Push the tube insert lightly into the tubing , avoiding any damage to the internal surface.
- 
- 3: The tube insert must be fully pushed in, until the shoulder is firmly flat against the end of the tube.

- 4: Remove the nut and olive from the fitting, and then slide nut, followed by olive over the tubing, ensuring the seat face has been reached.
- 5: Push nut and olive firmly against the fitting. Screw nut on until finger tight. (using the correct size spanner, tighten another 1 & 3/4 turns).
- 6: Now release the nut from the fitting to inspect that the olive has in fact penetrated the tube and created a visible seal.
- 7: Re-assembly can now take place as normal.

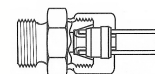
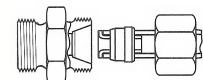

CAUTION: DO NOT OVERTIGHTEN, AS THIS CAN CAUSE SEVERE DAMAGE TO ALL COMPONENTS, ESPECIALLY THE TUBING.



COMPRESSION RANGE

ALUMINIUM SEALING RING



Part Ref	Thread Size
AL10	M10 x 1
AL12	M12 x 1.5
AL14	M14 x 1.5
AL16	M16 x 1.5
AL22	M22 x 1.5
AL26	M26 x 1.5

FIBRE SEALS



Part Ref	Tube OD	ID	OD
FS1219	15 mm	12 mm	19 mm
FS1420	16 mm	14 mm	20 mm

BONDING SEALS



Part Ref	Thread Size
BS4	M4 x 1
BS6	M6 x 1
BS8	M8 x 1
BS10	M10 x 1
BS12	M12 x 1.5
BS14	M14 x 1.5
BS16	M16 x 1.5
BS18	M18 x 1.5
BS22	M22 x 1.5
BSI4	1/4"
BSI6	3/8"
BSI8	1/2"

OLIVES / CUTTING RINGS



Part Ref	Part Ref	Tube OD
BRASS		
O4B	-	4 mm
O6B	O6	6 mm
O8B	O8	8 mm
O9B	-	9 mm
O10B	O10	10 mm
O12B	O12	12 mm
O15B	O15	15 mm
O16B	O16	16 mm
O18B	O18	18 mm
O20B	-	20 mm

TUBE NUTS AND TUBE INSERTS
ON FOLLOWING PAGE



COPPER SEALING RINGS



**ASSORTED
BOX REF:**

CRAB

Part Ref	Thread Size
CRI1	1/8"
CR6	M6 x 1
CR8	M8 x 1
CR10	M10 x 1
CR12	M12 x 1.5
CR14	M14 x 1.5
CR16	M16 x 1.5
CR18	M18 x 1.5
CR20	M20 x 1.5
CR22	M22 x 1.5
CR26	M26 x 1.5
CR32	M32 x 1.5

"O" RINGS



Part Ref	Thread Size
OR10	M10 x 1
OR12	M12 x 1.5
OR14	M14 x 1.5
OR16	M16 x 1.5
OR18	M18 x 1.5
OR22	M22 x 1.5
OR26	M26 x 1.5

THRUST RINGS ON
FOLLOWING PAGE TO BE
USED IN CONJUNCTION WITH



COMPRESSION RANGE NUT & OLIVE

TUBE INSERTS

Part Ref	Tube ID
TI2	2 mm
TI4	4 mm
TI6	6 mm
TI7	7 mm
TI7.5	7.5 mm
TI8	8 mm



Imperial inserts also available



Part Ref	Tube ID
TI9	9 mm
TI10	10 mm
TI11	11 mm
TI12	12 mm
TI14	14 mm

Tube inserts to be used with Din Spec Nylon tubing in Section 3



THRUST RINGS

Thrust Rings and 'O' Rings (pg.10) are used in conjunction with each other, resulting in a sealed connection



Part Ref	Thread Size	Part Ref	Thread Size
TR10	M10 x 1	TROR10	M10 x 1
TR12	M12 x 1.5	TROR12	M12 x 1.5
TR14	M14 x 1.5	TROR14	M14 x 1.5
TR16	M16 x 1.5	TROR16	M16 x 1.5
TR18	M18 x 1.5	TROR18	M18 x 1.5
TR22	M22 x 1.5	TROR22	M22 x 1.5
TR26	M26 x 1.5	TROR26	M26 x 1.5

PACKS OF 10 EACH



TUBE NUTS



Part Ref	Thread Size	Tube OD
TN4Z	M10 x 1	4 mm
TN6Z	M12 x 1.5	6 mm
TN8Z	M14 x 1.5	8 mm

Part Ref	Thread Size	Tube OD
TN9Z	M14 x 1.5	9 mm
TN10Z	M16 x 1.5	10 mm
TN12Z	M18 x 1.5	12 mm
TN15Z	M22 x 1.5	15 mm
TN16Z	M22 x 1.5	16 mm
TN18Z	M26 x 1.5	18 mm
TN20Z	M30 x 2	20 mm
TN22Z	M30 x 2	22 mm

BRAKE CHAMBER PORT ADAPTORS



SAF1-ALI

Part Ref	Part Ref	Leg type	Thread Size
Aluminium		Plastic	
SAF1-ALI	SAF1	Unequal	M16 x 1.5
SAF2-ALI	SAF2	Equal	M16 x 1.5
SAF3-ALI	N/A	Offset	M16 x 1.5



SAF3-ALI

COMPRESSION RANGE ASSORTED BOXES

PART REF: ABCS1



COMPRESSION EQUAL CONNECTORS

Contents Includes:

EC6Z (6 mm)	EC12Z (12 mm)	EC18Z (18 MM)
EC8Z (8 mm)	EC15Z (15 mm)	
EC10Z (10 mm)	EC16Z (16 mm)	

PART REF: TRA1



THRUST AND "O"RINGS

Contents Includes:

TR10 (10 mm)	TR14 (14 mm)	TR22 (22 mm)
OR10 (10 mm)	OR14 (14 mm)	OR22 (22 mm)
TR12 (12 mm)	TR16 (16 mm)	
OR12 (12 mm)	OR16 (16 mm)	

PART REF: OLA1



OLIVES (CUTTING RINGS)

Contents Includes:

O6B (6 mm)	O12B (12 mm)	O18B (18 mm)
O8B (8 mm)	O15B (15 mm)	
O10B (10 mm)	O16B (16 mm)	

PART REF: TIA1



TUBE INSERTS

Contents Includes:

T14 (4 mm)	T18 (8 mm)	T112 (12 mm)
T16 (6 mm)	T19 (9 mm)	T114 (14 mm)
T17 (7 mm)	T110 (10 mm)	
T17.5 (7.5 mm)	T111 (11 mm)	



All other parts in the Compression Section are available in assorted boxes made to your requirements

Empty Boxes and Racks Available



SECTION

3

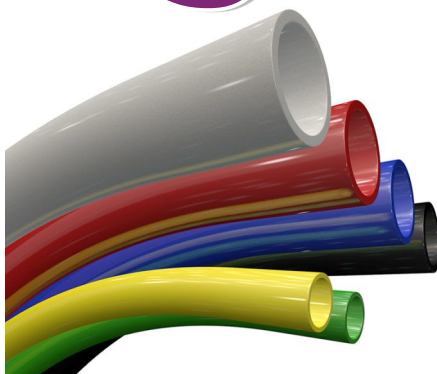

DIN SPEC NYLON TUBING





COILS

Available in 15 / 30 / 50 / 100 metre coils and also dispensing drums.
The Type 12 Nylon is can be used throughout the pneumatics industry, and is suitable for air brake, fuel and lube applications and can be supplied in both Metric and Imperial sizes in a number of colours. (Please ask if not listed)

DIN SPEC NYLON TUBING

Semi Rigid Nylon Tubing Type 12

- Manufactured in accordance to BS 5409, DIN 73378 & DIN 74324
 - Flexible, Lightweight and Durable
- Can be used over a wide range of temperatures
 - Resistant to a wide range of chemicals
 - High resistance to moisture absorption
 - Silicone Free

Part Ref	OD Size	ID Size	Colour
15 MTR COILS			
N41BK/15	4 mm	2.5 mm	BLACK
N41R/15	4 mm	2.5 mm	RED
N41Y/15	4 mm	2.5 mm	YELLOW
N41B/15	4 mm	2.5 mm	BLUE
N41G/15	4 mm	2.5 mm	GREEN
N41N/15	4 mm	2.5 mm	NATURAL

30 MTR COILS			
N41BK/30	4 mm	2.5 mm	BLACK
N41R/30	4 mm	2.5 mm	RED
N41Y/30	4 mm	2.5 mm	YELLOW
N41B/30	4 mm	2.5 mm	BLUE
N41G/30	4 mm	2.5 mm	GREEN
N41N/30	4 mm	2.5 mm	NATURAL

50 MTR COILS			
N41BK/50	4 mm	2.5 mm	BLACK
N41R/50	4 mm	2.5 mm	RED
N41Y/50	4 mm	2.5 mm	YELLOW
N41B/50	4 mm	2.5 mm	BLUE
N41G/50	4 mm	2.5 mm	GREEN
N41N/50	4 mm	2.5 mm	NATURAL

100 MTR COILS			
N41BK/100	4 mm	2.5 mm	BLACK
N41R/100	4 mm	2.5 mm	RED
N41Y/100	4 mm	2.5 mm	YELLOW
N41B/100	4 mm	2.5 mm	BLUE
N41G/100	4 mm	2.5 mm	GREEN
N41N/100	4 mm	2.5 mm	NATURAL

Max Work Pressure = 26 Bar
Max Burst Pressure = 104 Bar
Bend Radius = 25 mm

Part Ref	OD Size	ID Size	Colour
15 MTR COILS			
N61BK/15	6 mm	4 mm	BLACK
N61R/15	6 mm	4 mm	RED
N61Y/15	6 mm	4 mm	YELLOW
N61B/15	6 mm	4 mm	BLUE
N61G/15	6 mm	4 mm	GREEN
N61N/15	6 mm	4 mm	NATURAL

30 MTR COILS			
N61BK/30	6 mm	4 mm	BLACK
N61R/30	6 mm	4 mm	RED
N61Y/30	6 mm	4 mm	YELLOW
N61B/30	6 mm	4 mm	BLUE
N61G/30	6 mm	4 mm	GREEN
N61N/30	6 mm	4 mm	NATURAL

50 MTR COILS			
N61BK/50	6 mm	4 mm	BLACK
N61R/50	6 mm	4 mm	RED
N61Y/50	6 mm	4 mm	YELLOW
N61B/50	6 mm	4 mm	BLUE
N61G/50	6 mm	4 mm	GREEN
N61N/50	6 mm	4 mm	NATURAL

100 MTR COILS			
N61BK/100	6 mm	4 mm	BLACK
N61R/100	6 mm	4 mm	RED
N61Y/100	6 mm	4 mm	YELLOW
N61B/100	6 mm	4 mm	BLUE
N61G/100	6 mm	4 mm	GREEN
N61N/100	6 mm	4 mm	NATURAL

Max Work Pressure = 24 Bar
Max Burst Pressure = 96 Bar
Bend Radius = 35 mm

DIN SPEC NYLON TUBING - COILS

Part Ref	OD Size	ID Size	Colour
----------	---------	---------	--------

15 MTR COILS

N81BK/15	8 mm	6 mm	BLACK
N81R/15	8 mm	6 mm	RED
N81Y/15	8 mm	6 mm	YELLOW
N81B/15	8 mm	6 mm	BLUE
N81G/15	8 mm	6 mm	GREEN
N81N/15	8 mm	6 mm	NATURAL

30 MTR COILS

N81BK/30	8 mm	6 mm	BLACK
N81R/30	8 mm	6 mm	RED
N81Y/30	8 mm	6 mm	YELLOW
N81B/30	8 mm	6 mm	BLUE
N81G/30	8 mm	6 mm	GREEN
N81N/30	8 mm	6 mm	NATURAL

50 MTR COILS

N81BK/50	8 mm	6 mm	BLACK
N81R/50	8 mm	6 mm	RED
N81Y/50	8 mm	6 mm	YELLOW
N81B/50	8 mm	6 mm	BLUE
N81G/50	8 mm	6 mm	GREEN
N81N/50	8 mm	6 mm	NATURAL

100 MTR COILS

N81BK/100	8 mm	6 mm	BLACK
N81R/100	8 mm	6 mm	RED
N81Y/100	8 mm	6 mm	YELLOW
N81B/100	8 mm	6 mm	BLUE
N81G/100	8 mm	6 mm	GREEN
N81N/100	8 mm	6 mm	NATURAL

Max Work Pressure = 14 Bar / Min Burst Pressure = 56 Bar
Bend Radius = 45 mm

Part Ref	OD Size	ID Size	Colour
----------	---------	---------	--------

15 MTR COILS

N101BK/15	10 mm	8 mm	BLACK
N101R/15	10 mm	8 mm	RED
N101Y/15	10 mm	8 mm	YELLOW
N101B/15	10 mm	8 mm	BLUE
N101G/15	10 mm	8 mm	GREEN
N101N/15	10 mm	8 mm	NATURAL

30 MTR COILS

N101BK/30	10 mm	8 mm	BLACK
N101R/30	10 mm	8 mm	RED
N101Y/30	10 mm	8 mm	YELLOW
N101B/30	10 mm	8 mm	BLUE
N101G/30	10 mm	8 mm	GREEN
N101N/30	10 mm	8 mm	NATURAL

50 MTR COILS

N101BK/50	10 mm	8 mm	BLACK
N101R/50	10 mm	8 mm	RED
N101Y/50	10 mm	8 mm	YELLOW
N101B/50	10 mm	8 mm	BLUE
N101G/50	10 mm	8 mm	GREEN
N101N/50	10 mm	8 mm	NATURAL

100 MTR COILS

N101BK/100	10 mm	8 mm	BLACK
N101R/100	10 mm	8 mm	RED
N101Y/100	10 mm	8 mm	YELLOW
N101B/100	10 mm	8 mm	BLUE
N101G/100	10 mm	8 mm	GREEN
N101N/100	10 mm	8 mm	NATURAL

Max Work Pressure = 14 Bar / Min Burst Pressure = 56 Bar
Bend Radius = 65 mm

Part Ref	OD Size	ID Size	Colour
----------	---------	---------	--------

15 MTR COILS

N10125BK/15	10 mm	7.5 mm	BLACK
N10125R/15	10 mm	7.5 mm	RED
N10125Y/15	10 mm	7.5 mm	YELLOW
N10125B/15	10 mm	7.5 mm	BLUE
N10125G/15	10 mm	7.5 mm	GREEN
N10125N/15	10 mm	7.5 mm	NATURAL

30 MTR COILS

N10125BK/30	10 mm	7.5 mm	BLACK
N10125R/30	10 mm	7.5 mm	RED
N10125Y/30	10 mm	7.5 mm	YELLOW
N10125B/30	10 mm	7.5 mm	BLUE
N10125G/30	10 mm	7.5 mm	GREEN
N10125N/30	10 mm	7.5 mm	NATURAL

Max Work Pressure = 22 Bar / Min Burst Pressure = 88 Bar / Bend Radius = 60 mm

Part Ref	OD Size	ID Size	Colour
----------	---------	---------	--------

50 MTR COILS

N10125BK/50	10 mm	7.5 mm	BLACK
N10125R/50	10 mm	7.5 mm	RED
N10125Y/50	10 mm	7.5 mm	YELLOW
N10125B/50	10 mm	7.5 mm	BLUE
N10125G/50	10 mm	7.5 mm	GREEN
N10125N/50	10 mm	7.5 mm	NATURAL

100 MTR COILS

N10125BK/100	10 mm	7.5 mm	BLACK
N10125R/100	10 mm	7.5 mm	RED
N10125Y/100	10 mm	7.5 mm	YELLOW
N10125B/100	10 mm	7.5 mm	BLUE
N10125G/100	10 mm	7.5 mm	GREEN
N10125N/100	10 mm	7.5 mm	NATURAL

DIN SPEC NYLON TUBING - COILS



Part Ref	OD Size	ID Size	Colour
----------	---------	---------	--------

15 MTR COILS

N1015BK/15	10 mm	7 mm	BLACK
N1015R/15	10 mm	7 mm	RED
N1015Y/15	10 mm	7 mm	YELLOW
N1015B/15	10 mm	7 mm	BLUE
N1015G/15	10 mm	7 mm	GREEN
N1015N/15	10 mm	7 mm	NATURAL

30 MTR COILS

N1015BK/30	10 mm	7 mm	BLACK
N1015R/30	10 mm	7 mm	RED
N1015Y/30	10 mm	7 mm	YELLOW
N1015B/30	10 mm	7 mm	BLUE
N1015G/30	10 mm	7 mm	GREEN
N1015N/30	10 mm	7 mm	NATURAL

Max Work Pressure = 22 Bar / Min Burst Pressure = 88 Bar
Bend Radius = 70 mm

Part Ref	OD Size	ID Size	Colour
----------	---------	---------	--------

15 MTR COILS

N1215BK/15	12 mm	9 mm	BLACK
N1215R/15	12 mm	9 mm	RED
N1215Y/15	12 mm	9 mm	YELLOW
N1215B/15	12 mm	9 mm	BLUE
N1215G/15	12 mm	9 mm	GREEN
N1215N/15	12 mm	9 mm	NATURAL

30 MTR COILS

N1215BK/30	12 mm	9 mm	BLACK
N1215R/30	12 mm	9 mm	RED
N1215Y/30	12 mm	9 mm	YELLOW
N1215B/30	12 mm	9 mm	BLUE
N1215G/30	12 mm	9 mm	GREEN
N1215N/30	12 mm	9 mm	NATURAL

50 MTR COILS

N1215BK/50	12 mm	9 mm	BLACK
N1215R/50	12 mm	9 mm	RED
N1215Y/50	12 mm	9 mm	YELLOW
N1215B/50	12 mm	9 mm	BLUE
N1215G/50	12 mm	9 mm	GREEN
N1215N/50	12 mm	9 mm	NATURAL

Max Work Pressure = 21 Bar
Min Burst Pressure = 84 Bar
Bend Radius = 70 mm

Part Ref	OD Size	ID Size	Colour
----------	---------	---------	--------

15 MTR COILS

N142BK/15	14 mm	10 mm	BLACK
N142N/15	14 mm	10 mm	NATURAL

30 MTR COILS

N142BK/30	14 mm	10 mm	BLACK
N142N/30	14 mm	10 mm	NATURAL

14 x 1.5 mm available made to order !

Part Ref	OD Size	ID Size	Colour
----------	---------	---------	--------

15 MTR COILS

N1515BK/15	15 mm	12 mm	BLACK
N1515N/15	15 mm	12 mm	NATURAL

30 MTR COILS

N1515BK/30	15 mm	12 mm	BLACK
N1515N/30	15 mm	12 mm	NATURAL

Max Work Pressure = 20 Bar
Min Burst Pressure = 80 Bar
Bend Radius = 85 mm

Part Ref	OD Size	ID Size	Colour
----------	---------	---------	--------

15 MTR COILS

N162BK/15	16 mm	12 mm	BLACK
N162N/15	16 mm	12 mm	NATURAL

30 MTR COILS

N162BK/30	16 mm	12 mm	BLACK
N162N/30	16 mm	12 mm	NATURAL

Max Work Pressure = 18 Bar
Min Burst Pressure = 72 Bar
Bend Radius = 90 mm

Part Ref	OD Size	ID Size	Colour
----------	---------	---------	--------

15 MTR COILS

N182BK/15	18 mm	14 mm	BLACK
N182R/15	18 mm	14 mm	RED
N182Y/15	18 mm	14 mm	YELLOW
N182N/15	18 mm	14 mm	NATURAL

30 MTR COILS

N182BK/30	18 mm	14 mm	BLACK
N182R/30	18 mm	14 mm	RED
N182Y/30	18 mm	14 mm	YELLOW
N182N/30	18 mm	14 mm	NATURAL

Max Work Pressure = 16 Bar
Min Burst Pressure = 64 Bar
Bend Radius = 115 mm



DIN SPEC NYLON TUBING - COILS

Part Ref	OD Size	ID Size	Colour
15 MTR COILS			
N51BK/15	5 mm	3.3 mm	BLACK
N51N/15	5 mm	3.3 mm	NATURAL
30 MTR COILS			
N51BK/30	5 mm	3.3 mm	BLACK
N51N/30	5 mm	3.3 mm	NATURAL

Part Ref	OD Size	ID Size	Colour
15 MTR COILS			
N615BK/15	6 mm	3 mm	BLACK
N615N/15	6 mm	3 mm	NATURAL
30 MTR COILS			
N615BK/30	6 mm	3 mm	BLACK
N615N/30	6 mm	3 mm	NATURAL

Part Ref	OD Size	ID Size	Colour
15 MTR COILS			
N815BK/15	8 mm	5 mm	BLACK
N815N/15	8 mm	5 mm	NATURAL
30 MTR COILS			
N815BK/30	8 mm	5 mm	BLACK
N815N/30	8 mm	5 mm	NATURAL

Part Ref	OD Size	ID Size	Colour
15 MTR COILS			
N915BK/15	9 mm	6 mm	BLACK
N915N/15	9 mm	6 mm	NATURAL
30 MTR COILS			
N915BK/30	9 mm	6 mm	BLACK
N915N/30	9 mm	6 mm	NATURAL

Part Ref	OD Size	ID Size	Colour
15 MTR COILS			
N1115BK/15	11 mm	8 mm	BLACK
N1115N/15	11 mm	8 mm	NATURAL
30 MTR COILS			
N1115BK/30	11 mm	8 mm	BLACK
N1115N/30	11 mm	8 mm	NATURAL

Other Colours and Lengths
available upon request



Part Ref	OD Size	ID Size	Colour
15 MTR COILS			
N122BK/15	12 mm	8 mm	BLACK
N122N/15	12 mm	8 mm	NATURAL
30 MTR COILS			
N122BK/30	12 mm	8 mm	BLACK
N122N/30	12 mm	8 mm	NATURAL

Part Ref	OD Size	ID Size	Colour
15 MTR COILS			
N1315K/15	13 mm	10 mm	BLACK
N1315N/15	13 mm	10 mm	NATURAL
30 MTR COILS			
N1315BK/30	13 mm	10 mm	BLACK
N1315N/30	13 mm	10 mm	NATURAL

Part Ref	OD Size	ID Size	Colour
15 MTR COILS			
N1415BK/15	14 mm	11 mm	BLACK
N1415N/15	14 mm	11 mm	NATURAL
30 MTR COILS			
N1415BK/30	14 mm	11 mm	BLACK
N1415N/30	14 mm	11 mm	NATURAL

Part Ref	OD Size	ID Size	Colour
15 MTR COILS			
N152BK/15	15 mm	11 mm	BLACK
N152N/15	15 mm	11 mm	NATURAL
30 MTR COILS			
N152BK/30	15 mm	11 mm	BLACK
N152N/30	15 mm	11 mm	NATURAL

Part Ref	OD Size	ID Size	Colour
15 MTR COILS			
N2225BK/15	22 mm	17 mm	BLACK
30 MTR COILS			
N2225BK/30	22 mm	17 mm	BLACK

Part Ref	OD Size	ID Size	Colour
15 MTR COILS			
N283BK/15	28 mm	22 mm	BLACK
30 MTR COILS			
N283BK/30	28 mm	22 mm	BLACK



DISPENSING DRUMS

DIN SPEC NYLON TUBING

Semi Rigid Nylon Tubing Type 12

- Manufactured in accordance to BS 5409, DIN 73378 & DIN 74324
 - Flexible, Lightweight and Durable
- Can be used over a wide range of temperatures
 - Resistant to a wide range of chemicals
 - High resistance to moisture absorption
 - Silicone Free

Part Ref	OD Size	ID Size	Colour
----------	---------	---------	--------

1000 MTR DRUM

N41BK/1000	4 mm	2.5 mm	BLACK
N41R/1000	4 mm	2.5 mm	RED
N41Y/1000	4 mm	2.5 mm	YELLOW
N41B/1000	4 mm	2.5 mm	BLUE
N41G/1000	4 mm	2.5 mm	GREEN
N41N/1000	4 mm	2.5 mm	NATURAL

500 MTR DRUM

N61BK/500	6 mm	4 mm	BLACK
N61R/500	6 mm	4 mm	RED
N61Y/500	6 mm	4 mm	YELLOW
N61B/500	6 mm	4 mm	BLUE
N61G/500	6 mm	4 mm	GREEN
N61N/500	6 mm	4 mm	NATURAL

500 MTR DRUM

N81BK/500	8 mm	6 mm	BLACK
N81R/500	8 mm	6 mm	RED
N81Y/500	8 mm	6 mm	YELLOW
N81B/500	8 mm	6 mm	BLUE
N81G/500	8 mm	6 mm	GREEN
N81N/500	8 mm	6 mm	NATURAL

500 MTR DRUM

N10125BK/500	10 mm	2.5 mm	BLACK
N10125R/500	10 mm	2.5 mm	RED
N10125Y/500	10 mm	2.5 mm	YELLOW
N10125B/500	10 mm	2.5 mm	BLUE
N10125G/500	10 mm	2.5 mm	GREEN
N10125/500	10 mm	2.5 mm	NATURAL

Part Ref	OD Size	ID Size	Colour
----------	---------	---------	--------

300 MTR DRUM

N2151BK/300	12 mm	9 mm	BLACK
N1215R/300	12 mm	9 mm	RED
N1215Y/300	12 mm	9 mm	YELLOW

200 MTR DRUM

N1515BK/200	15 mm	12 mm	BLACK
-------------	-------	-------	-------

200 MTR DRUM

N162BK/200	16 mm	12 mm	BLACK
N162R/200	16 mm	12 mm	RED
N162Y/200	16 mm	12 mm	YELLOW

200 MTR COILS

N182BK/200	18 mm	14 mm	BLACK
N182R/200	18 mm	14 mm	RED
N182Y/200	18 mm	14 mm	YELLOW

External Diameter	Internal Diameter	Max Working Pressure	Minimum Burst Pressure	Weight Per Mtr	Bend Radius
4 mm	2.5 mm	26 Bar	104 Bar	0.008 Kg	25 mm
6 mm	4 mm	24 Bar	96 Bar	0.017 Kg	35 mm
8 mm	6 mm	14 Bar	56 Bar	0.023 Kg	45 mm
10 mm	7.5 mm	22 Bar	88 Bar	0.039 Kg	60 mm
12 mm	9 mm	21 Bar	84 Bar	0.055 Kg	70 mm
15 mm	12 mm	20 Bar	80 Bar	0.064 Kg	85 mm
16 mm	12 mm	18 Bar	72 Bar	0.100 Kg	90 mm
18 mm	14 mm	16 Bar	64 Bar	0.117 Kg	115 mm

Din Spec Nylon in drums lengths can be made to order in any colour required - Please ask for full details

Manufactured in the U.K



**Drum
Stands
Available**



IMPERIAL NYLON TUBING

Semi Rigid Nylon Tubing Type 12

- Manufactured in accordance to BS 5409, DIN 73378 & DIN 74324
- Flexible, Lightweight and Durable
- Can be used over a wide range of temperatures
- Resistant to a wide range of chemicals
- High resistance to moisture absorption
 - Silicone Free



15 MTR COILS



Part Ref	OD Size	ID Size	Colour
15 MTR COILS			
N1BK/15	1/8"	0.075"	BLACK
N1R/15	1/8"	0.075"	RED
N1Y/15	1/8"	0.075"	YELLOW
N1B/15	1/8"	0.075"	BLUE
N1G/15	1/8"	0.075"	GREEN
N1N/15	1/8"	0.075"	NATURAL
N3BK/15	3/16"	0.117"	BLACK
N3R/15	3/16"	0.117"	RED
N3Y/15	3/16"	0.117"	YELLOW
N3B/15	3/16"	0.117"	BLUE
N3G/15	3/16"	0.117"	GREEN
N3N/15	3/16"	0.117"	NATURAL
N4BK/15	1/4"	0.170"	BLACK
N4R/15	1/4"	0.170"	RED
N4Y/15	1/4"	0.170"	YELLOW
N4B/15	1/4"	0.170"	BLUE
N4G/15	1/4"	0.170"	GREEN
N4N/15	1/4"	0.170"	NATURAL
N5BK/15	5/16"	0.212"	BLACK
N5R/15	5/16"	0.212"	RED
N5Y/15	5/16"	0.212"	YELLOW
N5B/15	5/16"	0.212"	BLUE
N5G/15	5/16"	0.212"	GREEN
N5N/15	5/16"	0.212"	NATURAL
N6BK/15	3/8"	0.250"	BLACK
N6R/15	3/8"	0.250"	RED
N6Y/15	3/8"	0.250"	YELLOW
N6B/15	3/8"	0.250"	BLUE
N6G/15	3/8"	0.250"	GREEN
N6N/15	3/8"	0.250"	NATURAL

Part Ref	OD Size	ID Size	Colour
15 MTR COILS			
N8BK/15	1/2"	0.375"	BLACK
N8R/15	1/2"	0.375"	RED
N8Y/15	1/2"	0.375"	YELLOW
N8B/15	1/2"	0.375"	BLUE
N8G/15	1/2"	0.375"	GREEN
N8N/15	1/2"	0.375"	NATURAL
N10BK/15	5/8"	0.500"	BLACK
N10R/15	5/8"	0.500"	RED
N10Y/15	5/8"	0.500"	YELLOW
N10B/15	5/8"	0.500"	BLUE
N10G/15	5/8"	0.500"	GREEN
N10N/15	5/8"	0.500"	NATURAL
N12BK/15	3/4"	0.594"	BLACK
N12N/15	3/4"	0.594"	NATURAL
N16BK/15	1"	0.812"	BLACK
N16N/15	1"	0.812"	NATURAL

External Diameter	Internal Diameter	Max Working Pressure	Minimum Burst Pressure	Weight Per Mtr	Bend Radius
1/8"	0.075"	22 Bar	68 Bar	0.005 Kg	0.75"
3/16"	0.117"	23 Bar	69 Bar	0.011 Kg	0.75"
1/4"	0.170"	24 Bar	70 Bar	0.017 Kg	1"
5/16"	0.212"	25 Bar	71 Bar	0.028 Kg	1.5"
3/8"	0.250"	26 Bar	72 Bar	0.041 Kg	2"
1/2"	0.375"	27 Bar	73 Bar	0.057 Kg	2"
5/8"	0.500"	28 Bar	74 Bar	0.073 Kg	3.5"
3/4"	0.594"	29 Bar	75 Bar	0.109 Kg	6"
1"	0.812"	30 Bar	76 Bar	0.177 Kg	9"

Manufactured in the U.K





30 MTR COILS



IMPERIAL NYLON TUBING

Semi Rigid Nylon Tubing Type 12

- Manufactured in accordance to BS 5409, DIN 73378 & DIN 74324
 - Flexible, Lightweight and Durable
- Can be used over a wide range of temperatures
- Resistant to a wide range of chemicals
- High resistance to moisture absorption
 - Silicone Free

Part Ref	OD Size	ID Size	Colour
30 MTR COILS			
N1BK/30	1/8"	0.075"	BLACK
N1R/30	1/8"	0.075"	RED
N1Y/30	1/8"	0.075"	YELLOW
N1B/30	1/8"	0.075"	BLUE
N1G/30	1/8"	0.075"	GREEN
N1N/30	1/8"	0.075"	NATURAL
N3BK/30	3/16"	0.117"	BLACK
N3R/30	3/16"	0.117"	RED
N3Y/30	3/16"	0.117"	YELLOW
N3B/30	3/16"	0.117"	BLUE
N3G/30	3/16"	0.117"	GREEN
N3N/30	3/16"	0.117"	NATURAL
N4BK/30	1/4"	0.170"	BLACK
N4R/30	1/4"	0.170"	RED
N4Y/30	1/4"	0.170"	YELLOW
N4B/30	1/4"	0.170"	BLUE
N4G/30	1/4"	0.170"	GREEN
N4N/30	1/4"	0.170"	NATURAL
N5BK/30	5/16"	0.212"	BLACK
N5R/30	5/16"	0.212"	RED
N5Y/30	5/16"	0.212"	YELLOW
N5B/30	5/16"	0.212"	BLUE
N5G/30	5/16"	0.212"	GREEN
N5N/30	5/16"	0.212"	NATURAL
N6BK/30	3/8"	0.250"	BLACK
N6R/30	3/8"	0.250"	RED
N6Y/30	3/8"	0.250"	YELLOW
N6B/30	3/8"	0.250"	BLUE
N6G/30	3/8"	0.250"	GREEN
N6N/30	3/8"	0.250"	NATURAL

Part Ref	OD Size	ID Size	Colour
30 MTR COILS			
N8BK/30	1/2"	0.375"	BLACK
N8R/30	1/2"	0.375"	RED
N8Y/30	1/2"	0.375"	YELLOW
N8B/30	1/2"	0.375"	BLUE
N8G/30	1/2"	0.375"	GREEN
N8N/30	1/2"	0.375"	NATURAL
N10BK/30	5/8"	0.500"	BLACK
N10R/30	5/8"	0.500"	RED
N10Y/30	5/8"	0.500"	YELLOW
N10B/30	5/8"	0.500"	BLUE
N10G/30	5/8"	0.500"	GREEN
N10N/30	5/8"	0.500"	NATURAL
N12BK/30	3/4"	0.594"	BLACK
N12N/30	3/4"	0.594"	NATURAL
N16BK/30	1"	0.812"	BLACK
N16N/30	1"	0.812"	NATURAL

External Diameter	Internal Diameter	Max Working Pressure	Minimum Burst Pressure	Weight Per Mtr	Bend Radius
1/8"	0.075"	22 Bar	68 Bar	0.005 Kg	0.75"
3/16"	0.117"	23 Bar	69 Bar	0.011 Kg	0.75"
1/4"	0.170"	24 Bar	70 Bar	0.017 Kg	1"
5/16"	0.212"	25 Bar	71 Bar	0.028 Kg	1.5"
3/8"	0.250"	26 Bar	72 Bar	0.041 Kg	2"
1/2"	0.375"	27 Bar	73 Bar	0.057 Kg	2"
5/8"	0.500"	28 Bar	74 Bar	0.073 Kg	3.5"
3/4"	0.594"	29 Bar	75 Bar	0.109 Kg	6"
1"	0.812"	30 Bar	76 Bar	0.177 Kg	9"

Manufactured in the U.K



SECTION

4



PUSH IN NICKEL PNEUFIT NORGREN FITTINGS



Metric 4 mm - 14 mm OD Tube - Imperial 1/4" - 3/4" OD Tube

Very compact units - Easy tube insertion for rapid assembly of pneumatic circuits - Positive tube anchorage - Tapered threads are pre-coated with non-PTFE based sealant - Straight Adaptors feature internal hexagon for Allen Key - Silicone free O-rings

Technical Data

Operating Pressure: vacuum - 18 bar
(Dependant upon operating specification of tubing)

Operating Temperature: -20°C to + 80°C

Materials: Nickel plated brass for body and collet - Silicone free nitrile rubber 'O' ring



WARNING:
The Push-in tube fittings in the pneufit range **MUST NOT** be used in vehicle air braking



Range of tube sizes Metric

- Tube sizes
4 mm o/d
5 mm o/d
6 mm o/d
8 mm o/d
10 mm o/d
12 mm o/d
14 mm o/d
- Tubing types:
Polyamide (PA)
Polyurethane (PU)

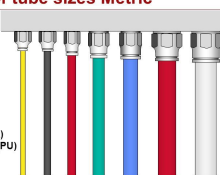

 NORGREN

PNEUFIT PUSH IN TUBE FITTINGS

STRAIGHT JOINERS



METRIC

Part Ref	Tube OD
100200400	4 mm
100200500	5 mm
100200600	6 mm
100200800	8 mm
100201000	10 mm
100201200	12 mm
100201400	14 mm

IMPERIAL

Part Ref	Tube OD
120200100	1/8"
120200200	5/32"
120200300	3/16"
120200400	1/4"
120200500	5/16"
120200600	3/8"
120200700	1/2"

EQUAL ELBOWS



METRIC

Part Ref	Tube OD
100400400	4 mm
100400500	5 mm
100400600	6 mm
100400800	8 mm
100401000	10 mm
100401200	12 mm
100401400	14 mm

IMPERIAL

Part Ref	Tube OD
120400100	1/8"
120400200	5/32"
120400300	3/16"
120400400	1/4"
120400500	5/16"
120400600	3/8"
120400700	1/2"

EQUAL TEES



METRIC

Part Ref	Tube OD
100600400	4 mm
100600500	5 mm
100600600	6 mm
100600800	8 mm
100601000	10 mm
100601200	12 mm
100601400	14 mm

IMPERIAL

Part Ref	Tube OD
120600100	1/8"
120600200	5/32"
120600300	3/16"
120600400	1/4"
120600500	5/16"
120600600	3/8"
120600700	1/2"

STRAIGHT ADAPTORS



BSP Taper Thread

Part Ref	Thread	Tube OD
101250418	1/8"	4 mm
101250428	1/4"	4 mm
101250518	1/8"	5 mm
101250528	1/4"	5 mm
101250618	1/8"	6 mm
101250628	1/4"	6 mm
101250818	1/8"	8 mm
101250828	1/4"	8 mm
101250838	3/8"	8 mm
101250848	1/2"	8 mm

Part Ref	Thread	Tube OD
101251018	1/8"	10 mm
101251028	1/4"	10 mm
101251038	3/8"	10 mm
101251048	1/2"	10 mm
101251228	1/4"	12 mm
101251238	3/8"	12 mm
101251248	1/2"	12 mm
101251438	3/8"	14 mm
101251448	1/2"	14 mm



PNEUFIT PUSH IN TUBE FITTINGS

STRAIGHT ADAPTOR



BSP Parallel Thread

Part Ref	Thread	Tube OD
102250405	M5 x 0.8	4 mm
102250406	M6	4 mm
102250408	M8	4 mm
102250410	M10	4 mm
102250418	1/8"	4 mm
102250428	1/4"	4 mm
102250505	M5 x 0.8	5 mm
102250506	M6	5 mm
102250518	1/8"	5 mm
102250528	1/4"	5 mm
102250606	M6	6 mm
102250608	M8	6 mm
102250610	M10	6 mm
102250618	1/8"	6 mm
102250628	1/4"	6 mm
102250818	1/8"	8 mm
102250828	1/4"	8 mm
102250838	3/8"	8 mm
102250848	1/2"	8 mm
102251018	1/8"	10 mm
102251028	1/4"	10 mm
102251038	3/8"	10 mm
102251048	1/2"	10 mm
102251228	1/4"	12 mm
102251238	3/8"	12 mm
102251248	1/2"	12 mm

Metric threaded studs
are manufactured by



STRAIGHT ADAPTOR



BSP Taper Thread

Part Ref	Thread BSP	Tube OD
121250118	1/8"	1/8"
121250128	1/4"	1/8"
121250318	1/8"	3/16"
121250328	1/4"	3/16"
121250418	1/8"	5/32"
121250428	1/4"	5/32"
121250418	1/8"	1/4"
121250428	1/4"	1/4"
121250438	3/8"	1/4"

FIXED ELBOW

BSP Taper Thread



Part Ref	Thread	Tube OD
101450418	1/8"	4 mm
101450428	1/4"	4 mm
101450518	1/8"	5 mm
101450528	1/4"	5 mm
101450618	1/8"	6 mm
101450628	1/4"	6 mm
101450818	1/8"	8 mm
101450828	1/4"	8 mm
101450838	3/8"	8 mm
101450848	1/2"	8 mm
101451018	1/8"	10 mm
101451028	1/4"	10 mm
101451038	3/8"	10 mm
101451048	1/2"	10 mm
101451228	1/4"	12 mm
101451238	3/8"	12 mm
101451248	1/2"	12 mm



PNEUFIT PUSH IN TUBE FITTINGS

SWIVEL ELBOWS



BSP Taper Thread

Part Ref	Thread	Tube OD
101470418	1/8"	4 mm
101470428	1/4"	4 mm
101470518	1/8"	5 mm
101470528	1/4"	5 mm
101470618	1/8"	6 mm
101470628	1/4"	6 mm
101470638	3/8"	6 mm
101470818	1/8"	8 mm
101470828	1/4"	8 mm
101470838	3/8"	8 mm
101470848	1/2"	8 mm
101471018	1/8"	10 mm
101471028	1/4"	10 mm
101471038	3/8"	10 mm
101471048	1/2"	10 mm
101471228	1/4"	12 mm
101471238	3/8"	12 mm
101471248	1/2"	12 mm
101471438	3/8"	14 mm
101471448	1/2"	14 mm

BSP Parallel Thread

Part Ref	Thread	Tube OD
102470418	1/8"	4 mm
102470428	1/4"	4 mm
102470518	1/8"	5 mm
102470528	1/4"	5 mm
102470618	1/8"	6 mm
102470628	1/4"	6 mm
102470818	1/8"	8 mm
102470828	1/4"	8 mm
102470838	3/8"	8 mm
102470848	1/2"	8 mm
102471018	1/8"	10 mm
102471028	1/4"	10 mm
102471038	3/8"	10 mm
102471048	1/2"	10 mm
102471228	1/4"	12 mm
102471238	3/8"	12 mm
102471248	1/2"	12 mm
102471438	3/8"	14 mm
102471448	1/2"	14 mm

BSP Taper Thread

Part Ref	Thread	Tube OD
121470118	1/8"	1/8"
121470318	1/8"	3/16"
121470418	1/8"	1/4"
121470818	1/8"	5/16"
121470328	1/4"	3/16"
121470428	1/4"	1/4"
121470828	1/4"	5/16"
121470628	1/4"	3/8"
121470728	1/4"	1/2"
121470638	3/8"	3/8"
121470648	1/2"	3/8"
121470738	3/8"	1/2"
121470748	1/2"	1/2"

SWIVEL ELBOWS



Part Ref	Thread	Tube OD
102470405	M5	4 mm
102470406	M6	4 mm
102470408	M8	4 mm
102470410	M10	4 mm



Metric threaded Elbows
are manufactured by

Part Ref	Thread	Tube OD
102470505	M5	5 mm
102470605	M5	6 mm
102470606	M6	6 mm
102470608	M8	6 mm
102470610	M10	6 mm



SWIVEL TEES



BSP Taper Thread

Part Ref	Thread	Tube OD
101670418	1/8"	4 mm
101670428	1/4"	4 mm
101670518	1/8"	5 mm
101670528	1/4"	5 mm
101670618	1/8"	6 mm
101670628	1/4"	6 mm
101670818	1/8"	8 mm
101670828	1/4"	8 mm
101670838	3/8"	8 mm
101670848	1/2"	8 mm
101671018	1/8"	10 mm
101671028	1/4"	10 mm
101671038	3/8"	10 mm
101671048	1/2"	10 mm
101671228	1/4"	12 mm
101671238	3/8"	12 mm
101671248	1/2"	12 mm

TUBE STEM



REDUCER

Part Ref	Stem	Tube OD
100230504	5 mm	4 mm
100230604	6 mm	4 mm
100230605	6 mm	5 mm
100230804	8 mm	4 mm
100230805	8 mm	5 mm
100230806	8 mm	6 mm
100231004	10 mm	4 mm
100231006	10 mm	6 mm
100231008	10 mm	8 mm
100231204	12 mm	4 mm
100231205	12 mm	5 mm
100231206	12 mm	6 mm
100231208	12 mm	8 mm
100231210	12 mm	10 mm
100231406	14 mm	6 mm
100231408	14 mm	8 mm
100231410	14 mm	10 mm
100231412	14 mm	12 mm

TUBE STEM



EXPANDER

Part Ref	Stem	Tube OD
100230406	4 mm	6 mm
100230608	6 mm	8 mm

BULKHEAD CONNECTOR



Part Ref	Tube OD
100290400	4 mm
100290500	5 mm
100290600	6 mm
100290800	8 mm
100291000	10 mm
100291200	12 mm
100291400	14 mm

FEMALE STUD



Part Ref	Thread	Tube OD
102260405	M5 x 0.8	4 mm
102260418	1/8"	4 mm
102260428	1/4"	4 mm
102260518	1/8"	5 mm
102260528	1/4"	5 mm
102260618	1/8"	6 mm
102260628	1/4"	6 mm

Part Ref	Thread	Tube OD
102260818	1/8"	8 mm
102260828	1/4"	8 mm
102261028	1/4"	10 mm
102261038	3/8"	10 mm
102261238	3/8"	12 mm
102261248	1/2"	12 mm



**AIGNEP
EQUAL
'Y'
CONNECTOR**



Part Ref	Tube OD
PFM1004M	4 mm
PFM1006M	6 mm
PFM1008M	8 mm
PFM1010M	10 mm

Other various Pneumatic fittings available upon request

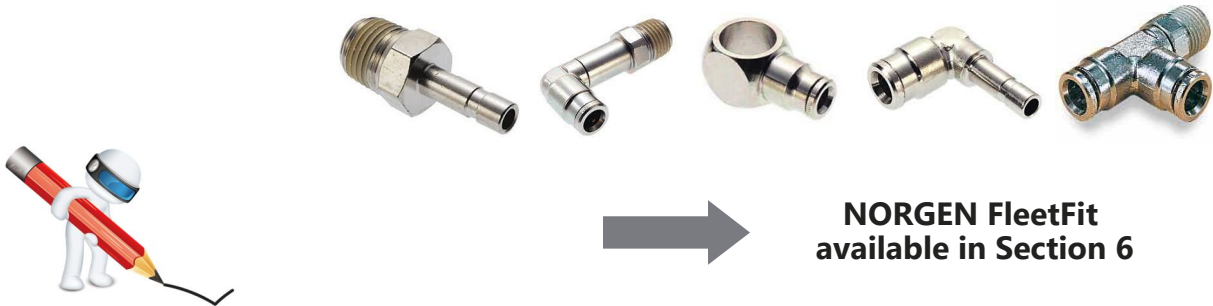

PNUEFIT ASSORTED WORKSHOP BOX



NORG100TAB

CONSISTS OF:

4 / 6 / 8 / 10 / 12 mm Connectors x 4

6 / 8 / 10 / 12 mm Tees x 2

1/8" x 6 mm Stud x 4

1/8" x 8 mm Stud x 4

1/8" x 10 mm Stud x 4

1/4" x 12 mm Stud x 4

1/8" x 6 mm Swivel Elbow x 4

1/8" x 8 mm Swivel Elbow x 4

1/8" x 10 mm Swivel Elbow x 4

1/4" x 12 mm Swivel Elbow x 4

1/4" Male x 1/8" Female Adaptor x 4

SECTION

5



AIR RESERVOIRS & ACCESSORIES



AIR RESERVOIRS & ACCESSORIES

STRAP MOUNTED

(EACH OF BELOW
REQUIRES A PAIR OF STRAPS)



Part Ref	Volume (Litre)	Length (mm)	Diameter (mm)
* ALL PORTS ARE METRIC THREAD M22 x 1.5 *			
AR5	5	215	206
AR10	10	370	206
AR15	15	530	206
AR20	20	690	206
AR20SP	20	500	246
AR30	30	720	246
AR40	40	620	310
AR40L246	40	940	246
AR40L276	40	760	276
AR50	50	748	310
AR60	60	895	310
AR 60L246	60	1352	246
AR 60L276	60	1110	276
AR 60L310	60	895	310
AR 60396	60	580	396
AR 80	80	750	396
AR100	100	915	396
AR120	120	1067	396

'U' BOLT & SADDLES

Part Ref	To Suit (mm)
ATSU310P	310
(* P = PLASTIC COATED)	



STRAP & SADDLES

1 PIECE

Part Ref	To Suit (mm)
ATS206OP	206
ATS246OP	246
ATS276OP	276
ATS310OP	310
ATS396OP	396



STRAP & SADDLES

2 PIECE

Part Ref	To Suit (mm)
ATS206	206
ATS246	246
ATS276	276
ATS310	310
ATS396	396

AIR RESERVOIRS & ACCESSORIES

END MOUNTED

Part Ref	Volume (Litre)	Length (mm)	Diameter (mm)
----------	----------------	-------------	---------------

* ALL PORTS ARE METRIC THREAD M22 x 1.5 *

AR20EM	20	685	206
AR38EM	38	815	246
AR45EM	45	700	300
AR50EM	50	733	300
AR60EM	60	888	300



SIDE MOUNTED



Part Ref	Volume (Litre)	Length (mm)	Diameter (mm)
----------	----------------	-------------	---------------

* ALL PORTS ARE METRIC THREAD M22 x 1.5 *

AR20SM	20	685	206
AR38SM	38	815	246
AR50SM	50	733	300
AR60SM5P	60	888	300
AR60SMDEN	60	888	300
AR60SMSDC	60	888	300

ALUMINIUM AIR TANKS

Aluminium Air Reservoirs are available upon request and all dimensional drawings to suit the desired Part for all tanks listed. All Aluminium tanks are strapped mounted and plastic coated straps (on previous page) or protective rubber is needed



Part Ref: ALURFS1

1 MTR Protective Strip for Strap

ACCESSORIES



Part Ref: TPM22T

M22 x 1.5 Test Point



Part Ref: TTC3

M22 x 1.5 Drain Tap with 6ft Cable



Part Ref: TT3T

M22 x 1.5 Drain Tap with Pull Ring



Part Ref: BP22B

M22 x 1.5 Blanking Plug



Part Ref: AD22

M22 x 1.5 Auto Drain

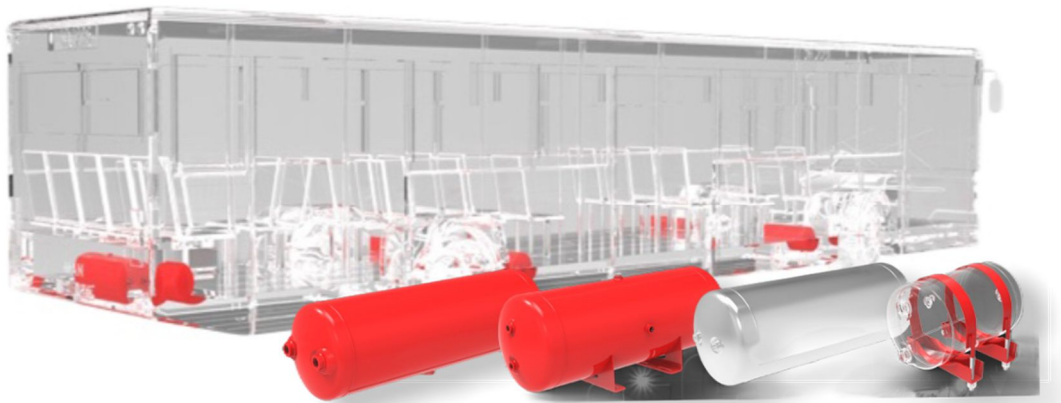

SECTION 6

FLEETFIT ■ BRASS PUSH IN FITTINGS

Metric 6 mm - 18 mm OD Tube - Imperial 1/4" - 3/4" OD Tube

- Simple tube connection and disconnection
no tools required
- Easy identification with all collets marked with tube sizes
 - Corrosion Resistant
 - Reduced assembly time saves time/labour
 - Ease of tube insertion in restricted areas
 - TUV Approved

INFO Technical Data

Maximum Working Pressure: 0 to 10 bar (0 to 150 psi)

Operating Temperature: -40°C to + 100°C

Materials:

Brass body, Tube support, & collet
Low Nitrile 'O' ring
Precoat 5 Thread Sealant



The swivel feature should be used for positioning purposes only and should not be used as a rotating joint.



HOW TO...



Installation - Tube Connection & Disconnection

1.
Ensure that the end of the tube is cut square and is free from burrs.

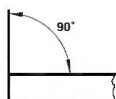

2.
Push the tube through the collect into the fitting.



3.
Continue pushing the tube through the 'O' ring until it bottoms on the tube stop. Then pull back on the tube to reinforce the collet teeth gripping action.



4.
To disconnect - First ensure there is no air present. Push the tube into the fitting until it bottoms on the tube stop. Then hold down the collet and withdraw the tube.





FLEETFIT PUSH IN TUBE FITTINGS

Installation - Tube Connection & Disconnection

1.
Ensure that the end of the tube is cut square and is free from burrs.

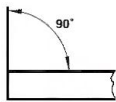

2.
Push the tube through the collet into the fitting.



3.
Continue pushing the tube through the 'O' ring until it bottoms on the tube stop. Then pull back on the tube to reinforce the collet teeth gripping action.



4.
To disconnect - First ensure there is no air present. Push the tube into the fitting until it bottoms on the tube stop. Then hold down the collet and withdraw the tube.



EQUAL CONNECTORS

METRIC JOINERS



Part Ref	Tube OD
97450304	6 mm
97450305	8 mm
97450313	9 mm
97450306	10 mm
97450336	11 mm
97450307	12 mm
97450392	14 mm
97450315	15 mm
97450308	16 mm

IMPERIAL JOINERS



Part Ref	Tube OD
94450303	3/16"
94450304	1/4"
94450306	3/8"
94450307	1/2"
94450308	5/8"
94450309	3/4"

METRIC EQUAL ELBOW



Part Ref	Tube OD
97451104	6 mm
97451105	8 mm
97451106	10 mm
97451107	12 mm
97451115	15 mm
97451108	16 mm

BULKHEAD CONNECTOR



Part Ref	Thread	Tube OD
97450704	M15 x 1.0	6 mm
97450705	M18 x 1.5	8 mm
97450706	M20 x 1.5	10 mm
97450707	M24 x 1.5	12 mm
97450708	M30 x 1.5	16 mm

METRIC UNEQUAL JOINERS

Part Ref	Tube OD
97450447	8 x 6 mm
97450448	10 x 6 mm
97450456	10 x 8 mm
97450457	12 x 8 mm
97450464	12 x 10 mm

IMPERIAL EQUAL ELBOW

Part Ref	Tube OD
94451104	1/4"
94451106	3/8"
94451107	1/2"



FLEETFIT PUSH IN TUBE FITTINGS

METRIC - IMPERIAL MALE STUD COUPLINGS



Part Ref	Thread	Tube OD
94466633	M12 x 1.5	1/4"
94466635	M16 x 1.5	1/4"
94466638	M22 x 1.5	1/4"
94466653	M12 x 1.5	3/8"
94466655	M16 x 1.5	3/8"
94466658	M22 x 1.5	3/8"
94466665	M16 x 1.5	1/2"
94466668	M22 x 1.5	1/2"

MALE STUDS IMPERIAL X METRIC



Part Ref	Thread	Tube OD
BSP		
97453004	1/8"	6 mm
97453010	1/4"	6 mm
97453005	1/8"	8 mm
97453011	1/4"	8 mm
97453019	3/8"	8 mm
97453012	1/4"	10 mm
97453020	3/8"	10 mm
97453029	1/2"	10 mm
97453013	1/4"	12 mm
97453030	1/2"	12 mm

STUD ELBOWS IMPERIAL x METRIC



Part Ref	Thread	Tube OD
BSP		
97433011	1/4"	8 mm
97433012	1/4"	10 mm



Other sizes can be adapted to your requirements upon request

TEE ADAPTORS (HOBBS)



Part Ref	Thread Male	Thread Female
36083201	M12 x 1.5	M12 x 1.5
36083202	M16 x 1.5	M16 x 1.5
36083203	M22 x 1.5	M22 x 1.5

STUD TEE ADAPTORS (HOBBS)



Part Ref	Thread	Tube OD
3 PIECE ONLY		
97443916	M12 x 1.5	10 mm
97443901	M16 x 1.5	10 mm
97443902	M22 x 1.5	10 mm
97443904	M16 x 1.5	12 mm
97443906	M22 x 1.5	12 mm

SIDE TEE ADAPTORS (HOBBS)



Part Ref	Thread Male	Thread Female
36074306	M12 x 1.5	M12 x 1.5
36074301	M16 x 1.5	M16 x 1.5
36074305	M22 x 1.5	M22 x 1.5

ASSORTED STRAIGHTS Part Ref:

ABNSF1



METRIC - METRIC MALE STUD COUPLINGS



Part Ref	Thread	Tube OD
97466631	M10 x 1	6 mm
97466633	M12 x 1.5	6 mm
97466635	M16 x 1.5	6 mm
97466638	M22 x 1.5	6 mm
97466641	M10 x 1	8 mm
97466643	M12 x 1.5	8 mm
97466645	M16 x 1.5	8 mm
97466648	M22 x 1.5	8 mm
97466651	M10 x 1	10 mm
97466653	M12 x 1.5	10 mm
97466655	M16 x 1.5	10 mm
97466658	M22 x 1.5	10 mm
97466665	M16 x 1.5	12 mm
97466668	M22 x 1.5	12 mm
97466670	M22 x 1.5	15 mm
97466675	M22 x 1.5	16 mm
97466679	M16 x 1.5	16 mm
97466680	M22 x 1.5	18 mm

METRIC - METRIC MALE STUD ELBOWS



Part Ref	Thread	Tube OD
97413831*	M10 x 1	6 mm
97413833*	M12 x 1.5	6 mm
97413835*	M16 x 1.5	6 mm
97413838*	M22 x 1.5	6 mm
97413841*	M10 x 1	8 mm
97413843	M12 x 1.5	8 mm
97413845	M16 x 1.5	8 mm
97413848	M22 x 1.5	8 mm
97413851*	M10 x 1	10 mm
97413853	M12 x 1.5	10 mm
97413855	M16 x 1.5	10 mm
97413858	M22 x 1.5	10 mm
97413865	M16 x 1.5	12 mm
97413868	M22 x 1.5	12 mm
97413870	M22 x 1.5	15 mm
97413875	M22 x 1.5	16 mm
97413879	M16 x 1.5	16 mm
97413880	M22 x 1.5	18 mm

* TWO PIECE ONLY *

EQUAL TEE JOINERS



Part Ref	Tube OD
97451404	6 mm
97451405	8 mm
97451406	10 mm
97451407	12 mm
97451408	16 mm



Other Norgren parts are available upon request including a full range of valves



SECTION 7

AIR - ELECTRICAL - E.B.S - A.B.S COILS ADAPTORS - SOCKETS - PLUGS



Handwriting practice lines consisting of multiple horizontal blue lines.

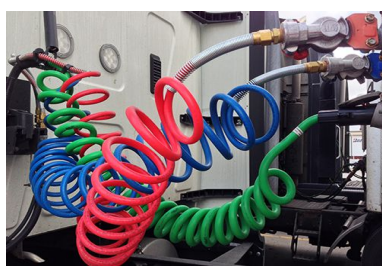

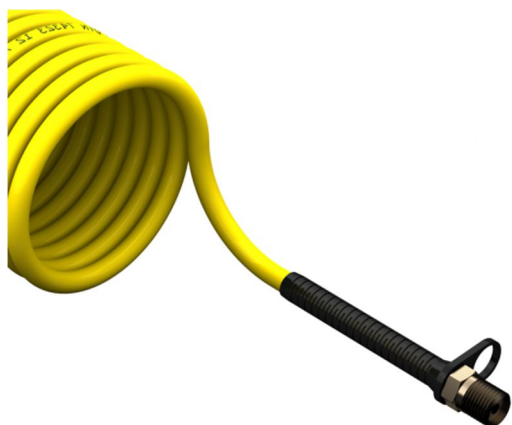

Manufactured from heat and light stabilised Type 12 Nylon to precise tolerances in accordance with DIN 74323, DIN 73378 & DIN 74324.

High resistance to moisture absorption.

Resistant to a wide range of chemicals.



Emergency Trailer Lines = Red Service Trailer Lines = Yellow Auxiliary Trailer Lines = Blue

Part Ref	Coils	Working Length	Mandrel	Thread Size
----------	-------	----------------	---------	-------------

RED COILS

ABC168R	16 Turn	3.6 Metre	90 mm	1/2" BSP
ABC228R	22 Turn	4.9 Metre	90 mm	1/2" BSP
ABC328R	32 Turn	11.3 Metre	130 mm	1/2" BSP
ABC1616R	16 Turn	3.6 Metre	90 mm	M16 x 1.5
ABC2216R	22 Turn	4.9 Metre	90 mm	M16 x 1.5
ABC3216R	32 Turn	11.3 Metre	130 mm	M16 x 1.5
ABC1622R	16 Turn	3.6 Metre	90 mm	M22 x 1.5
ABC2222R	22 Turn	4.9 Metre	90 mm	M22 x 1.5
ABC3222R	32 Turn	11.3 Metre	130 mm	M22 x 1.5
ABC1618R	16 Turn	3.6 Metre	90 mm	F18 x 1.5
ABC2218R	22 Turn	4.9 Metre	90 mm	F18 x 1.5
ABC3218R	32 Turn	11.3 Metre	130 mm	F18 x 1.5

YELLOW COILS

ABC168Y	16 Turn	3.6 Metre	90 mm	1/2" BSP
ABC228Y	22 Turn	4.9 Metre	90 mm	1/2" BSP
ABC328Y	32 Turn	11.3 Metre	130 mm	1/2" BSP
ABC1616Y	16 Turn	3.6 Metre	90 mm	M16 x 1.5
ABC2216Y	22 Turn	4.9 Metre	90 mm	M16 x 1.5
ABC3216Y	32 Turn	11.3 Metre	130 mm	M16 x 1.5
ABC1622Y	16 Turn	3.6 Metre	90 mm	M22 x 1.5
ABC2222Y	22 Turn	4.9 Metre	90 mm	M22 x 1.5
ABC3222Y	32 Turn	11.3 Metre	130 mm	M22 x 1.5
ABC1618Y	16 Turn	3.6 Metre	90 mm	F18 x 1.5
ABC2218Y	22 Turn	4.9 Metre	90 mm	F18 x 1.5
ABC3218Y	32 Turn	11.3 Metre	130 mm	F18 x 1.5



Coils ordered in a minimum of 100 each colour can be manufactured bespoke with your own company name and details.

22 Turn Blue Coils Also Available.



Eurocoil - Unicoil

- Incorporating 12mm nylon tube manufactured to DIN 74323, DIN 73378 & DIN 74324 standards.
- DIN spec compression end fittings including colour-coded anti-kink springs.

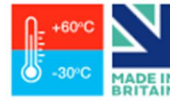

BLACK - RED EMERGENCY



Part Ref	Coils	Working Length	Mandrel	Thread Size
ABC2218BKR	20 Turn	4 Metre	90 mm	M18 x 1.5 (F)
ABC2618BKR	26 Turn	5.8 Metre	90 mm	M18 x 1.5 (F)







BLACK - YELLOW SERVICE

Part Ref	Coils	Working Length	Mandrel	Thread Size
ABC2218BKY	20 Turn	4 Metre	90 mm	M18 x 1.5 (F)
ABC2618BKY	26 Turn	5.8 Metre	90 mm	M18 x 1.5 (F)



The above coils are supplied with M18 female ends enabling you to order the correct fittings required to Brand

EUROCOIL - TO TRUCK BRAND INCLUDING FITTINGS

Part Ref	Spring Colour	Truck Brand	Thread A	Thread B
ABC22DAFR	RED		M18 x 1.5 (F)	M16 x 1.5 (M)
ABC22DAFY	YELLOW		M18 x 1.5 (F)	M16 x 1.5 (M)
ABC22IVER	RED		M16 x 1.5 (M)	M18 x 1.5 Bulkhead
ABC22IVEY	YELLOW		M16 x 1.5 (M)	M18 x 1.5 Bulkhead
ABC22MANR	RED		M18 x 1.5 Bulkhead	M16 x 1.5 Bulkhead
ABC22MANY	YELLOW		M18 x 1.5 Bulkhead	M16 x 1.5 Bulkhead
ABC22MERC	RED		M18 x 1.5 (F)	M16 x 1.5 (M)
ABC22MERCY	YELLOW		M18 x 1.5 (F)	M16 x 1.5 (M)
ABC22RENR	RED		M16 x 1.5 (M)	M16 x 1.5 (M)
ABC22RENY	YELLOW		M16 x 1.5 (M)	M16 x 1.5 (M)
ABC22SCANR	RED		M16 x 1.5 (M)	M18 x 1.5 Bulkhead
ABC22SCANY	YELLOW		M16 x 1.5 (M)	M18 x 1.5 Bulkhead
ABC22VOLR	RED		M16 x 1.5 (M)	M16 x 1.5 (M)
ABC22VOLY	YELLOW		M16 x 1.5 (M)	M16 x 1.5 (M)

ANTI-KINK COMPACT COILS



Part Ref	Coils	Mandrel	Colour	Thread Size
ABC2218AKR	20 Turn	50 mm	RED	M18 x 1.5 (F)
ABC2218AKY	20 Turn	50 mm	YELLOW	M18 x 1.5 (F)



ADAPTORS FOR EURO - UNICOILS

MALE - MALE





Part Ref	Thread
MMA718Z	1/2" BSP x M18
MMA1618Z	M18 x M16
MMA2218Z	M18 x M22



BULKHEAD

Part Ref	Thread
BA1618Z	M18 x M16
BA1818Z	M18 x M18

FITTINGS TO TRUCK BRAND

Brand	Fitting Required	Qty
	MMA1618Z	1
	MMA1618Z	1
	BA1818Z	1
	BA1818Z	1
	BA1618Z	1
	MMA1618Z	1

Brand	Fitting Required	Qty
	MMA1618Z	2
	MMA1618Z	1
	BA1818Z	1
	MMA1618Z	2

AIR COIL GRIPS

Part ref:
GRIP1

COMPLETE WITH
FITTINGS



AIR COIL SOCK PROTECTION SLEEVE

CPS (Med) 40-90 mm
CPSL (Large) 90-120 mm



Part ref:
ABCADAP1
ASSORTED
COIL ENDS



Part Ref	Thread	Qty in Box
MMA718Z	1/2" BSP x M18	4
MMA1618Z	M18 x M16	4
MMA2218Z	M18 x M22	4
BA1618Z	M18 x M16	2
BA1818Z	M18 x M18	2

PART REF: ABCA1

COMPLETE COIL COUPLING KIT

FITTED WITH BSAU138b:2000 STANDARD COUPLINGS

EMERGENCY LINE



Provides vehicle safety, lower operational costs & 'Peace of Mind'.

Specify coupling kits from Air Brake Connections meet the new standard and are manufactured and tested by the principal supplier and designers.

SERVICE LINE



ABCA1 - CONTENTS

- 1 x Din Red 22 Turn x M22 x 1.5 Air Coil
- 1 x self Seal Valve M22 x 1.5 (SSVCA22FH)
- 1 x Male 'c' M22 x 1.5 (MC22FH)



- 1 x Din Red 22 Turn x M22 x 1.5 Air Coil
- 1 x self Seal Valve Male M22 x 1.5 (SSV22FH)
- 1 x Female 'c' M22 x 1.5 (FCOV22FH)



Benefits:

- Reduces fitting time.
- No tools required.
- Couplings supplied tested.
- Din spec euro coils c/w spring guard.
- Colour coded standards attached to couplings.
- Eliminates leakage.
- Reduce chance of tampering.



Part Ref: AB480

Twin Durable Euro Coil
(Yellow inside the Red)



ELECTRICAL COILS



Part Ref	Turns	Type	Plug Type
EC2NP16	16	Normal	Plastic
EC2SP16	16	Supplementary	Plastic
EC2NP22	22	Normal	Plastic
EC2SP22	22	Supplementary	Plastic

Part Ref	Turns	Type	Plug Type
EC2NA16	16	Normal	Aluminium
EC2SA16	16	Supplementary	Aluminium
EC2NA22	22	Normal	Aluminium
EC2SA22	22	Supplementary	Aluminium



ELECTRICAL PLUGS - 7 PIN - 24V



Part Ref	Type	Plug Type
EPA24N	Normal	Aluminium
EPA24S	Supplementary	Aluminium
EPP24N	Normal	Plastic
EPP24S	Supplementary	Plastic

ELECTRICAL SOCKETS - 7 PIN

Part Ref	Type	Plug Type
ESA24N	Normal	Aluminium
ESA24S	Supplementary	Aluminium
ESP24N	Normal	Plastic
ESP24S	Supplementary	Plastic



E.B.S COILS - PLUGS - SOCKETS

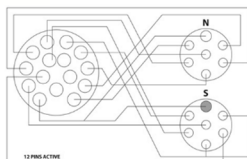

Part Ref	Pins	Description
EBSEC	7 Pin	EBS Electrical Coil 3.5 MTR Working Length
EBSEC15	15 Pin	EBS Electrical Coil 3.5 MTR Working Length
EBS/TAC	15 / 7 / 7 PIN	Twin Adaptor Coil (24V) 3.5 MTR Working Length
EBSP	7 PIN	EBS Plug - Screw Terminal
EBSSS	7 PIN	EBS Socket - Screw Terminal

SECTION

8

GREASE NIPPLES & ACCESSORIES





GREASE NIPPLES & ACCESSORIES

STRAIGHTS



Part Ref	Thread
GN2	1/8" BSP
GN4	1/4" BSP
GN4UNF	1/4" UNF
GN5BSF	5/16" BSP
GN6	6 x 1 mm
GN8	8 x 1 mm
GN8125	8 x 1.25 mm
GN101	10 x 1 mm
GN1015	10 x 1.5 mm

45 DEGREE



Part Ref	Thread
GN452	1/8" BSP
GN454	1/4" BSP
GN545BSF	5/16" BSP
GN4561	6 x 1 mm
GN4581	8 x 1 mm
GN458125	8 x 1.25 mm
GN45101	10 x 1 mm
GN451015	10 x 1.5 mm

90 DEGREE



Part Ref	Thread
GN902	1/8" BSP
GN904	1/4" UNF
GN9061	6 x 1 mm
GN9081	8 x 1 mm
GN90101	10 x 1 mm
GN901015	10 x 1.5 mm

EXTENSION



Part Ref	Thread
GNEXT	1/8" BSP

HOOK ON



Part Ref	Thread
GNHO1	1/8" BSP

SLIDE ON



Part Ref
SON

Grease Gun - Part Ref: GGU



Assorted box of Grease Nipples
Part Ref: **GNAB**



11" Grease Gun Hose
Part: **GGH11R**
20" Grease Gun Hose
Part: **GGH20R**
12" Grease Gun Flexi Hose - Part: GFH12



SHUT OFF TAPS

Part Ref	Thread
SOT4	1/4" BSP
SOT6	3/8" BSP
SOT8	1/2" BSP
SOT12	3/4" BSP
SOT16	1" BSP
SOT20	1 1/4" BSP
SOT22	M22 x 1.5
SOT24	1 1/2"
SOT16R	M16 x 1.5
SOT16Y	M16 x 1.5
SOT8Y	1/2" BSP

1/4 TURN



PLASTIC BALL VALVE

Part Ref	Tube OD
PBV0404	4 mm
PBV0606	6 mm
PBV0808	8 mm
PBV1010	10 mm
PBV1212	12 mm



MANUAL

SILENCER

Sintered Bronze



Part Ref	Thread
MS1	1/8"
MS2	1/4"
MS3	3/8"
MS4	1/2"

SILENCER

Flat



Part Ref	Thread
MS1F	1/8"
MS2F	1/4"
MS3F	3/8"
MS4F	1/2"

BREATHER

IMPERAL & METRIC



Part Ref	Thread
EX2	1/8"
EX4	1/4"
BR12	M12 x 1.5
BR16	M16 x 1.5

PRESSURE SWITCHES & BOOTS

Hexagon



Part Ref	Thread
PS1	1/8"

MAX 350 BAR

Knurled



Part Ref	Thread
PS2	1/8"



Part Ref	To Suit
PS1B	PS1
PS2B	PS2

CLIPS & CLAMPS

'O' CLIPS



Part Ref	Size	Size
	INCHES	MM
OC4	1/4"	5 - 7
OC5	5/16"	7 - 9
OC6	3/8"	8 - 11
OC7	7/16"	9 - 12
OC8	1/2"	11 - 13
OC9	9/16"	13 - 15
OC10	5/8"	15 - 18
OC12	3/4"	17 - 20
OC14	7/8"	20 - 23
OC16	1"	23 - 26

O CLIPS PLIERS
Part Ref: OCP2



ASSORTED BOX
Part Ref: OCAB



TUBE CLAMPS



ASSORTED BOX
Part Ref: TCAB



Part Ref	Tube OD
TC6	6 mm
TC8	8 mm
TC10	10 mm
TC12	12 mm
TC16	16 mm
TC18	18 mm
TC25	25 mm

WORM DRIVE - JUBILEE CLIPS



Part Ref	Standard Ref	Adjustment
WD67	OOO	9.5 - 12 mm
WD810	MOO	11 - 16 mm
WD812	OO	13 - 20 mm
WD1014	O	16 - 22 mm
WD1216	OX	18 - 25 mm
WD1418	1A	22 - 30 mm
WD1622	1	25 - 35 mm
WD1826	1X	30 - 40 mm

Part Ref	Standard Ref	Adjustment
WD2032	2A	35 - 50 mm
WD2434	2	40 - 55 mm
WD2836	2X	45 - 60 mm
WD3444	3	55 - 70 mm
WD3850	3X	60 - 80 mm
WD4456	4	70 - 90 mm
WD5064	4X	85 - 100 mm
WD5676	5	90 - 120 mm



BOLT CLIP - WD25

TO SUIT 13mm ID Hose

ASSORTED BOX

Part Ref: **WDAB**



QUICK RELEASE AIR IN LINE CAB DUST BLOWER

Part Ref: **ICB**



IN LINE 6MM TEE OFF CAB BLOWER FOR DEBRIS
REMOVAL, GREAT FOR SMALL SPACES .

4 MTR COIL

MAX PRESSURE - 10kg/CM2

CABLE TIES

Packs of 100

Part Ref	Size
CT4	4" (2.5 x 100mm)
CT6	6" (3.6 x 140mm)
CT8	8" (4.8 x 200mm)
CT12	12" (4.8 x 300mm)
CT15H	15" (7.6 x 370mm)
CT15L	15" (7.6 x 370mm)
CT17	17" (4.8 x 430mm)



SECTION 9



MALLEABLE ADAPTORS

BLANKING PLUGS



Part Ref	Thread
MIBP802	1/8"
MIBP804	1/4"
MIBP806	3/8"
MIBP808	1/2"
MIBP812	3/4"
MIBP816	1"

FEMALE ELBOWS



Part Ref	Thread
MIFE622	1/8"
MIFE644	1/4"
MIFE666	3/8"
MIFE688	1/2"
MIFE612	3/4"
MIFE616	1"

REDUCING FEMALE SOCKET



Part Ref	Thread
MIFR442	1/4" - 1/8"
MIFR464	3/8" - 1/4"
MIFR484	1/2" - 1/4"
MIFR846	1/2" - 3/8"
MIFR124	3/4" - 1/4"
MIFR128	3/4" - 1/2"

MALE - FEMALE - ELBOWS



Part Ref	Thread
MIMF722	1/8"
MIMF744	1/4"
MIMF766	3/8"
MIMF788	1/2"
MIMF712	3/4"
MIMF716	1"



**All Malleable Iron products
Are suitable for all industrial
uses such as:**

air, gas, water, diesel, petrol

**Can also be used
In airbrake application**

*Larger sizes are available
upon request*

FEMALE SOCKETS



Part Ref	Thread
MIFS422	1/8"
MIFS444	1/4"
MIFS466	3/8"
MIFS488	1/2"
MIFS412	3/4"
MIFS416	1"

MALLEABLE IRON RANGE

EQUAL

Part Ref	Thread
MIHN522	1/8"
MIHN544	1/4"
MIHN566	3/8"
MIHN588	1/2"
MIHN512	3/4"
MIHN516	1"

HEXAGON NIPPLES

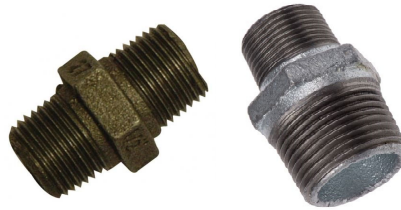

UNEQUAL

Part Ref	Thread
MIHN542	1/4" x 1/8"
MIHN546	1/4" x 3/8"
MIHN548	1/4" x 1/2"
MIHN568	3/8" x 1/2"
MIHN5124	3/4" x 1/4"
MIHN5126	3/4" x 3/8"
MIHN5128	3/4" x 1/2"
MIHN51612	3/4" x 1"

Part Ref	Thread
MIRB342	1/4" x 1/8"
MIRB362	3/8" x 1/8"
MIRB364	3/8" x 1/4"
MIRB384	1/2" x 1/4"
MIRB386	1/2" x 3/8"
MIRB3124	3/4" x 1/4"
MIRB3126	3/4" x 3/8"
MIRB3128	3/4" x 1/2"
MIRB1612	1" x 3/4"

REDUCING BUSH



FEMALE TEES



Part Ref	Thread
MIT322	1/8"
MIT344	1/4"
MIT366	3/8"
MIT388	1/2"
MIT312	3/4"
MIT316	1"

SEALANTS



Part Ref: BPS100

Brake & Pipe Sealant is PTFE modified and aerobic adhesive for sealing pipe fittings and threaded joints

Part Ref: PTFE

PTFE sealing tape ensures air tight sealing on all type of thread seals



SECTION



MARKER BOARDS – CONSPICUITY TAPE – REFLECTORS



MARKER BOARDS

ECE 70 REGULATION REAR ALUMINIUM MARKER BOARDS

PART REF: RMB1



130mm x 1130mm
(Supplied Individually)
Self Adhesive Part Ref: RMB1SA

PART REF: RMB5



195mm x 1130mm
(Supplied Individually)
Self Adhesive Part Ref: RMB5SA

PART REF: RMB23



130mm x 565mm
(Supplied In Pairs)
Self Adhesive Part Ref: RMB23SA

PART REF: RMB67



195mm x 565mm
(Supplied In Pairs)
Self Adhesive Part Ref: RMB67SA

PART REF: RMB4

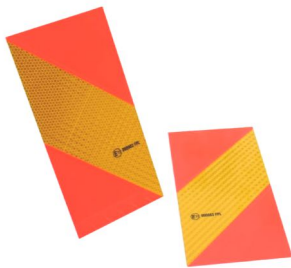

130mm x 282mm
(Supplied In Fours)
Self Adhesive Part Ref: RMB4SA

PART REF: RMB8

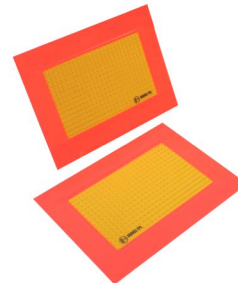

195mm x 282mm
(Supplied In Fours)
Self Adhesive Part Ref: RMB8SA

MARKER BOARDS

LONG VEHICLE



WIDE LOAD



HIGHWAY MAINTENANCE

Part Ref	Description	Qty	Dimensions
HMM	Highway Maintenance	1	225mm x 1265mm
LVM	Long Vehicle	1	225mm x 1265mm
LVM2	Long Vehicle	2	250mm x 525mm
MMM	Motorway Maintenance	1	225mm x 1265mm
MMM2	Motorway Maintenance	2	250mm x 525mm
RMBRS	Rear Steering	1	225mm x 1265mm
SMM	Slow Moving	1	225mm x 1265mm
SMM2	Slow Moving	2	250mm x 525mm
SVM	Slow Vehicle	1	225mm x 1265mm
SVM2	Slow Vehicle	2	250mm x 525mm
WLM	Wide Load	1	225mm x 1265mm
WLM2	Wide Load	2	250mm x 525mm
WVM	Wide Vehicle	1	225mm x 1265mm
WVM2	Wide Vehicle	2	250mm x 525mm

PART REF: FRPM



Front / Rear Load Protection Markers
610mm x 610mm
Flexible Part Ref: FRPMV

PART REF: RMBAL

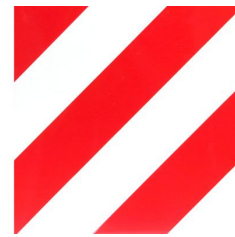

Abnormal Load Sign
500mm x 500mm

HAZARDOUS PLATES (Hazchem)

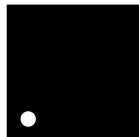

Various Hazchem plates and holders available upon request, both vertical and horizontal

CONTOUR TAPE - RIGID



Part Ref	Colour	App	Length
CT/A12550	Amber	Side	12.5 Mtr
CT/A5050	Amber	Side	50 Mtr
CT/R12550	Red	Rear	12.5 Mtr
CT/R5050	Red	Rear	50 Mtr
CT/W12550	White	Front	12.5 Mtr
CT/W5050	White	Front	50 Mtr

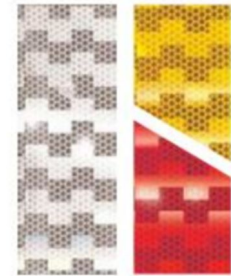

CONSPICUITY TAPE APPLICATION - ECE-104



CONTOUR TAPE - CURTAIN



Part Ref	Colour	App	Length
CCT/A5050	Amber	Curtain	50 Mtr
CCT/R5050	Red	Curtain	50 Mtr
CCT/W5050	White	Curtain	50 Mtr

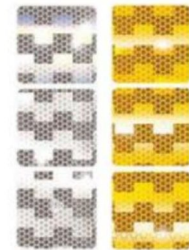

INFO

- ECE - 104 Approved
 - 50 mm Wide
- Metalised reflective material
- For LGV Side curtains

REFLECTORS

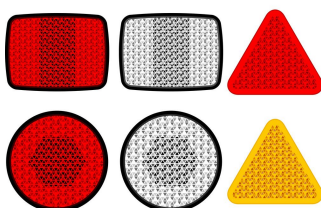

- Various Reflectors available
 - Self adhesive
 - Bolt ons
- Rectangular and circular
- Amber - Red - White



SECTION



PUSH IN COMPOSITE NORGREN FITTINGS

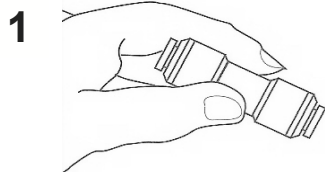

1 Select the part required for use from the range of Push Fit Connectors

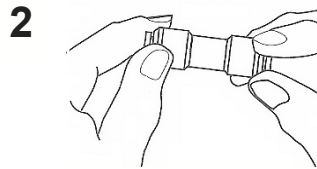

2 Visually inspect the part to ensure no obstruction is present

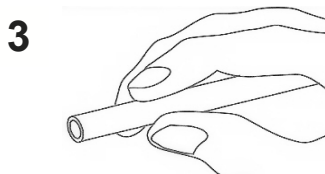

3 Prepare the tubing ready for insertion ensuring that the end is cut square

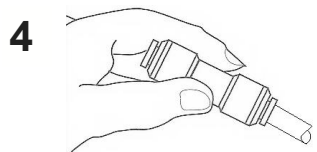

4 Insert tube, ensuring you have reached the stop position, now pull back

The Plastic & Metal range can be used for a variety of uses including: Air, Water, Vacuum and Fuel.

However under no circumstances can be used for carrying acids.



Not to be used on Braking Systems



TECHNICAL INFORMATION

Maximum Working Pressure 0 To 10 Bar

Temperature Range 0°C To +60°C

ASSORTED BOXES

Part Ref: PFMASB (Straights)



Part Ref: PFMAEB (Elbows)



Part Ref: PFMATB (Tees)



PUSH IN PLASTIC - COMPOSITE NORGREN FITTINGS

STRAIGHTS



Part Ref	Tube OD
PFM4NR	4 mm
PFM5NR	5 mm
PFM6NR	6 mm
PFM8NR	8 mm
PFM10NR	10 mm
PFM12NR	12 mm
PFM16NR	16 mm

ELBOWS



Part Ref	Tube OD
PFM54NR	4 mm
PFM56NR	6 mm
PFM58NR	8 mm
PFM510NR	10 mm
PFM512NR	12 mm
PFM516NR	16 mm

TEES



Part Ref	Tube OD
PFM74NR	4 mm
PFM75NR	5 mm
PFM76NR	6 mm
PFM78NR	8 mm
PFM710NR	10 mm
PFM712NR	12 mm
PFM716NR	16 mm

STEM REDUCER



Part Ref	Stem OD	Tube OD
PFM154NR	5 mm	4 mm
PFM164NR	6 mm	4 mm
PFM184NR	8 mm	4 mm
PFM186NR	8 mm	6 mm
PFM1104NR	10 mm	4 mm
PFM1106NR	10 mm	6 mm
PFM1108NR	10 mm	8 mm
PFM11210NR	12 mm	10 mm

STEM EXPANDER

Part Ref	Stem OD	Tube OD
PFM146NR	4 mm	6 mm
PFM168NR	6 mm	8 mm

ELBOW STEM CONNECTOR



Part Ref	Stem	Tube OD
PFM544NR	4 mm	4 mm
PFM566NR	6 mm	6 mm
PFM588NR	8 mm	8 mm

'Y' CONNECTOR (DIVIDER)



Part Ref	Tube OD
PFM1004NR	4 mm
PFM1006NR	6 mm
PFM1008NR	8 mm
PFM1010NR	10 mm
PFM1012NR	12 mm

UNEQUAL CONNECTOR



Part Ref	Tube OD	Tube OD
PFM64NR	6 mm	4 mm
PFM86NR	8 mm	6 mm
PFM106NR	10 mm	6 mm
PFM108NR	10 mm	8 mm
PFM1210NR	12 mm	10 mm

COLLET RELEASE TOOL KEYCHAIN

Part Ref: CRT



PUSH IN PLASTIC - COMPOSITE NORGREN FITTINGS

MALE STUD

Part Ref	Thread	Tube OD
PMS04M5	M5	4 mm
PMS04M6	M6	4 mm
PMS0402NR	1/8"	4 mm
PMS0404NR	1/4"	4 mm
PMS06M5	M5	6 mm
PMS06M6	M6	6 mm
PMS0602NR	1/8"	6 mm
PMS0604NR	1/4"	6 mm
PMS0606NR	3/8"	6 mm
PMS0802NR	1/8"	8 mm



Part Ref	Thread	Tube OD
PMS0804NR	1/4"	8 mm
PMS0806NR	3/8"	8 mm
PMS0808NR	1/2"	8 mm
PMS1002NR	1/8"	10 mm
PMS1004NR	1/4"	10 mm
PMS1006NR	3/8"	10 mm
PMS1008NR	1/2"	10 mm
PMS1204NR	1/4"	12 mm
PMS1206NR	3/8"	12 mm
PMS1208NR	1/2"	12 mm

SWIVEL ELBOW

Part Ref	Thread	Tube OD
PMSE04M5	M5	4 mm
PMSE04M6	M5	4 mm
PMSE0402NR	1/8"	4 mm
PMSE 0404NR	1/4"	4 mm
PMSE06M5	M5	6 mm
PMSE06M6	M5	6 mm
PMSE0602NR	1/8"	6 mm
PMSE0604NR	1/4"	6 mm
PMSE0606NR	3/8"	6 mm



Part Ref	Thread	Tube OD
PMSE0802NR	1/8"	8 mm
PMSE0804NR	1/4"	8 mm
PMSE0806NR	3/8"	8 mm
PMSE1004NR	1/4"	10 mm
PMSE1006NR	3/8"	10 mm
PMSE1008NR	1/2"	10 mm
PMSE1204NR	1/4"	12 mm
PMSE1206NR	3/8"	12 mm
PMSE1208NR	1/2"	12 mm

FEMALE STUD

Part Ref	Thread	Tube OD
PMFS0402NR	1/8"	4 mm
PMFS0404NR	1/4"	4 mm
PMFS0504NR	1/4"	5 mm
PMFS0602NR	1/8"	6 mm
PMFS0604NR	1/4"	6 mm
PMFS0606NR	3/8"	6 mm
PMFS0802NR	1/8"	8 mm



Part Ref	Thread	Tube OD
PMFS0804NR	1/4"	8 mm
PMFS0806NR	3/8"	8 mm
PMFS1004NR	1/4"	10 mm
PMFS1006NR	3/8"	10 mm
PMFS1008NR	1/2"	10 mm
PMFS1206NR	3/8"	12 mm
PMFS1208NR	1/2"	12 mm

PUSH IN PLASTIC - COMPOSITE NORGREN FITTINGS

Part Ref	Thread	Tube OD
PMSY0402NR	1/8"	4 mm
PMSY0404NR	1/4"	4 mm
PMSY0602NR	1/8"	6 mm
PMSY0604NR	1/4"	6 mm
PMSY0606NR	3/8"	6 mm

SWIVEL 'Y'



Part Ref	Thread	Tube OD
PMSY0802NR	1/8"	8 mm
PMSY0804NR	1/4"	8 mm
PMSY1004NR	1/4"	10 mm
PMSY1006NR	3/8"	10 mm
PMSY1008NR	1/2"	10 mm

Part Ref	Thread	Tube OD
PMT04M5	M5	4 mm
PMT0402NR	1/8"	4 mm
PMT0404NR	1/4"	4 mm
PMT04M6	M6	6 mm
PMT0602NR	1/8"	6 mm
PMT0604NR	1/4"	6 mm
PMT0802NR	1/8"	8 mm
PMT0804NR	1/4"	8 mm

SWIVEL TEE



Part Ref	Thread	Tube OD
PMT0806NR	3/8"	8 mm
PMT1002NR	1/8"	10 mm
PMT1004NR	1/4"	10 mm
PMT1006NR	3/8"	10 mm
PMT1008NR	1/2"	10 mm
PMT1204NR	1/4"	12 mm
PMT1206NR	3/8"	12 mm
PMT1208NR	1/2"	12 mm

Part Ref	Thread	Tube OD
PMSRT04M5	M5	4 mm
PMSRT0402NR	1/8"	4 mm
PMSRT0404NR	1/4"	4 mm
PMSRT04M6	M6	6 mm
PMSRT0602NR	1/8"	6 mm
PMSRT0604NR	1/4"	6 mm
PMSRT0802NR	1/8"	8 mm
PMSRT0804NR	1/4"	8 mm

SWIVEL SIDE TEE



Part Ref	Thread	Tube OD
PMSRT0806NR	3/8"	8 mm
PMSRT1002NR	1/8"	10 mm
PMSRT1004NR	1/4"	10 mm
PMSRT1006NR	3/8"	10 mm
PMSRT1008NR	1/2"	10 mm
PMSRT1204NR	1/4"	12 mm
PMSRT1206NR	3/8"	12 mm
PMSRT1208NR	1/2"	12 mm

BLANKING PLUG



Part Ref	Tube OD
PFM44NR	4 mm
PFM46NR	6 mm
PFM48NR	8 mm
PFM410NR	10 mm
PFM412NR	12 mm

BLANKING CAP



Part Ref	Tube OD
PFMC4NR	4 mm
PFMC6NR	6 mm
PFMC8NR	8 mm
PFMC10NR	10 mm
PFMC12NR	12 mm

STEM CONNECTOR



Part Ref	Tube OD
PFMS4NR	4 mm
PFMS6NR	6 mm
PFMS8NR	8 mm
PFMS10NR	10 mm
PFMS12NR	12 mm

SECTION

12

BRAKE PIPE - CUNIFER - BLEED SCREWS

90/10 CUPRO NICKEL BRAKING TUBE

METRIC

25ft Coil

Part Ref	Tube OD
CN5	5 mm
CN6	6 mm
CN8	8 mm
CN10	10 mm
CN12	12 mm

Produced to international standards and conforms to:

BS2871 pt 2, SMMT C5B, ASTM A254, SAE J2527

Produced from 90% Copper and 10% Nickel alloy, this tubing is seamless & carries a guarantee for the vehicle life

It is easily flared, flexible and allows easy manipulation even in situ



IMPERIAL

25ft Coil

Part Ref	Tube OD
CN90103	3/16"
CN90104	1/4"
CN90105	5/16"
CN90106	3/8"
CN90108	1/2"

BLEED SCREWS - IMPERIAL & METRIC

Part Ref	Thread	Length
8402	10 x 1 mm	30 mm
8403	10 x 1 mm	37 mm
8411	10 x 1 mm	27 mm
8405	8 x 1.25 mm	28 mm
8404	7 x 1 mm	28 mm
8410	6 x 1 mm	37 mm
8409	6 x 1 mm	28 mm



Part Ref	Thread	Length
8406	1/4" x 28 TPI	28 mm
8401	3/8" x 24 TPI	32 mm
8408	3/8" x 24 TPI	37 mm
8407	7/16" x 20 TPI	37 mm

BRAKE PIPE FITTINGS

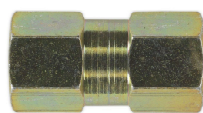

Part Ref	Thread	Part Ref	Thread	Part Ref	Thread	Part Ref	Thread
MALE CONNECTOR		FEMALE CONNECTOR		3 WAY CONNECTOR		4 WAY CONNECTOR	
8200	10 x 1 mm	8301	3/8" x 24 TPI	8303	3/8" x 24 TPI	8304	3/8" x 24 TPI
8201	3/8" x 24 TPI	8302	10 x 1 mm	8305	10 x 1 mm	8306	10 x 1 mm
		8307	12 x 1 mm				

BRAKE PIPE FITTINGS



MALE PIPE NUTS

Part Ref	Thread	Length
----------	--------	--------

3/16" 4.75 mm Tube Size

8001	3/8" x 24 TPI	21 mm
8002	3/8" x 20 TPI	23 mm
8020	3/8" x 24 TPI (TTE Short)	16 mm
8022	3/8" x 24 TPI (TTE Long)	21 mm
8015	7/16" x 24 TPI	20 mm
8019	7/16" x 20 TPI	22 mm
8003	10 x 1.25 mm (Long)	20 mm
8004	10 x 1.25 mm (Short)	17 mm
8023	10 x 1.25 mm TTE	21 mm
8005	10 x 1 mm Long	23 mm
8006	10 x 1 mm Long TTE	22 mm
8007	10 x 1 mm Short	16 mm
8008	10 x 1 mm TTE	16 mm
8009	12 x 1 mm	21 mm

1/4" 6 mm Tube Size

8010	7/16" x 20 TPI	24 mm
8016	1/2" x 20 TPI	27 mm
8021	1/2" x 20 TPI (Short)	18 mm



Part Ref	Thread	Length
----------	--------	--------

8018	12 x 1 mm	21 mm
8025	12 x 1 mm	39 mm
8028	14 x 1.5 mm	25 mm

5/16" 8 mm Tube Size

8011	1/2" x 20 TPI	28 mm
8012	1/2" x 20 TPI (Short)	23 mm
8024	1/2" x 20 TPI	18 mm
8026	14 x 1.5 mm	26 mm

3/8" 10 mm Tube Size

8013	5/8" x 18 TPI	20 mm
------	---------------	-------

1/2" 12.7 mm Tube Size

8014	3/4" x 16 TPI	27 mm
------	---------------	-------

FEMALE BRAKE NUTS

Part Ref	Thread	Length
----------	--------	--------

3/16" 4.75 mm Tube Size

8101	3/8" x 24 TPI	17 mm
8102	10 x 1 mm	18 mm
8107	12 x 1 mm	20 mm

1/4" 6 mm Tube Size

8103	7/16" x 20 TPI	24 mm
8108	12 x 1 mm	19 mm

5/16" 8 mm Tube Size

8104	1/2" x 20 TPI	22 mm
------	---------------	-------



Part Ref	Thread	Length
----------	--------	--------

3/8" 10 mm Tube Size

8105	5/8" x 18 TPI	25 mm
------	---------------	-------

1/2" 12.7 mm Tube Size

8106	3/4" x 16 TPI	
------	---------------	--

SECTION



PUSH IN PLASTIC FITTINGS





PUSH IN PLASTIC FITTINGS

The John Guest Push in connectors will provide a secure seal with out the use of any special tools

They can be used for a wide range of materials, Including: Nylon, Plastic, Calibrated Cooper, Bundy Tubing

We Recommend that they only be used for carrying the following: Air, Water, Petro, Diesel and Oil

Please note that under any circumstances they are not to be used for carrying acids or to be used for Braking Systems.

INSTRUCTIONS



CUT THE PIPE SQUARE
(You can use a TCB1 - TCB2 - TCB2/G)



PUSH UP TO PIPE STOP



PULL TO CHECK SECURE
(TEST THE SYSTEM BEFORE USE)



TO DISCONNECT, ENSURE THE SYSTEM IS DE-PRESSURISED. PUSH THE COLLET TOWARDS THE FITTING AND REMOVE THE PIPE
(FITTING THEN CAN BE RE-USED)

TECHNICAL



MAXIMUM WORKING PRESSURE	10 BAR
MINIMUM BURST PRESSURE	25 BAR
TEMPERATURE RANGE	-25 TO +75°C

PUSH IN PLASTIC FITTINGS

STRAIGHT CONNECTOR



ELBOW CONNECTOR



TEE CONNECTOR



UNEQUAL CONNECTOR



Part Ref	Tube OD	Part Ref	Tube OD	Part Ref	Tube OD	Part Ref	Tube OD
PFM4	4 mm	PFM54	4 mm	PFM74	4 mm	mm	
PFM5	5 mm	PFM55	5 mm	PFM75	5 mm	PFM64	6 x 4
PFM6	6 mm	PFM56	6 mm	PFM76	6 mm	PFM84	8 x 4
PFM8	8 mm	PFM58	8 mm	PFM78	8 mm	PFM86	8 x 6
PFM10	10 mm	PFM510	10 mm	PFM710	10 mm	PFM106	10 x 6
PFM12	12 mm	PFM512	12 mm	PFM712	12 mm	PFM108	10 x 8
PFM15	15 mm	PFM515	15 mm	PFM715	15mm	PFM128	12 x 8
PFM18	18 mm	PFM518	18 mm	PFM718	18 mm	PFM1210	12 x 10
PFM22	22 mm						

ASSORTED BOX

Part ref:

PFMASB/GUEST



CONTENTS:

4 mm X 4 10 mm X 4
6 mm X 4 12 mm X 4
8 mm X 4 15 mm X 2

BLANKING PLUG



Part Ref	Tube OD
PFM44	4 mm
PFM45	5 mm
PFM46	6 mm
PFM48	8 mm
PFM410	10 mm
PFM412	12 mm
PFM415	15 mm
PFM418	18 mm
PFM422	22 mm

BULKHEAD CONNECTOR



Part Ref	Tube OD
PFM24	4 mm
PFM25	5 mm
PFM26	6 mm
PFM28	8 mm
PFM210	10 mm
PFM212	12 mm

COLLET RELEASE TOOL

Part ref:

CRT



JG Speedfit®



**NOT SUITABLE FOR
AIR BRAKES**

PUSH IN PLASTIC FITTINGS

STEM REDUCER



Part Ref	Stem	Tube OD
PFM154	5 mm	4 mm
PFM164	6 mm	4 mm
PFM165	6 mm	5 mm
PFM184	8 mm	4 mm
PFM185	8 mm	5 mm
PFM186	8 mm	6 mm
PFM1106	10 mm	6 mm
PFM1108	10 mm	8 mm
PFM1128	12 mm	8 mm
PFM11210	12 mm	10 mm
PFM11510	15 mm	10 mm
PFM11512	15 mm	12 mm

MALE STUD



Part Ref	Thread	Tube OD
PFM214	1/8"	4 mm
PFM244	1/4"	4 mm
PFM215	1/8"	5 mm
PFM245	1/4"	5 mm
PFM216	1/8"	6 mm
PFM246	1/4"	6 mm
PFM218	1/8"	8 mm
PFM248	1/4"	8 mm
PFM268	3/8"	8 mm
PFM2410	1/4"	10 mm
PFM2610	3/8"	10 mm
PFM2810	1/2"	10 mm
PFM2612	3/8"	12 mm
PFM2812	1/2"	12 mm

SWIVEL ELBOW



Part Ref	Thread	Tube OD
PFM624	1/8"	4 mm
PFM644	1/4"	4 mm
PFM625	1/8"	5 mm
PFM645	1/4"	5 mm
PFM626	1/8"	6 mm
PFM646	1/4"	6 mm
PFM628	1/8"	8 mm
PFM648	1/4"	8 mm
PFM668	3/8"	8 mm
PFM6410	1/4"	10 mm
PFM6610	3/8"	10 mm
PFM6810	1/2"	10 mm
PFM6612	3/8"	12 mm
PFM6812	1/2"	12 mm

Y CONNECTOR



Part Ref	Tube OD
PFM1004	4 mm
PFM1006	6 mm
PFM1008	8 mm
PFM1010	10 mm
PFM1012	12 mm

STEM ADAPTOR



Part Ref	Thread	Tube OD
PFM314	1/8"	4 mm
PFM344	1/4"	4 mm
PFM315	1/8"	5 mm
PFM345	1/4"	5 mm
PFM316	1/8"	6 mm
PFM346	1/4"	6 mm
PFM318	1/8"	8 mm

Part Ref	Thread	Tube OD
PFM348	1/4"	8 mm
PFM368	3/8"	8 mm
PFM3410	1/4"	10 mm
PFM3610	3/8"	10 mm
PFM3810	1/2"	10 mm
PFM3612	3/8"	12 mm
PFM3812	1/2"	12 mm



**NOT SUITABLE FOR
AIR BRAKES**

PUSH IN PLASTIC FITTINGS

STEM REDUCER



Part Ref	Thread	Tube OD	Part Ref	Thread	Tube OD
PFM824	1/8"	4 mm	PFM848	1/4"	8 mm
PFM844	1/4"	4 mm	PFM868	3/8"	8 mm
PFM825	1/8"	5 mm	PFM8410	1/4"	10 mm
PFM845	1/4"	5 mm	PFM8610	3/8"	10 mm
PFM826	1/8"	6 mm	PFM8810	1/2"	10 mm
PFM846	1/4"	6 mm	PFM8612	3/8"	12 mm
PFM828	1/8"	8 mm	PFM8812	1/2"	12 mm

STEM ELBOW



Part Ref	Tube OD
PFM544	4 mm
PFM566	6 mm
PFM588	8 mm
PFM51010	10 mm
PFM51212	12 mm



RING MAIN SYSTEM

WALL BOX
Part Ref:
JGWALLBOX1/2
4 x 1/2" Ports



3m RIGID TUBE

Part Ref	OD	ID
RMT12	12 mm	9 mm
RMT15	15 mm	12.5 mm
RMT18	18 mm	14 mm
RMT22	22 mm	18 mm
RMT28	28 mm	23 mm

STRAIGHT CONNECTOR



Part Ref	Tube OD
PM0412E	12 mm
PM0415E	15 mm
PM0418E	18 mm
PM0422E	22 mm
PM0428E	28 mm

WINGBACK BLOCK



Part Ref	Tube OD	Thread
PM15WB	15 mm	1/2"
PM22WB	22 mm	3/4"

EQUAL TEE



Part Ref	Tube OD
PM0212E	12 mm
PM0215E	15 mm
PM0218E	18 mm
PM0222E	22 mm
PM0228E	28 mm

STRAIGHT ADAPTOR



Part Ref	Tube OD	Thread
MM011504N	15 mm	1/2"
MM012206N	22 mm	3/4"
MM012808N	28 mm	1"

EQUAL ELBOW



Part Ref	Tube OD
PM0312E	12 mm
PM0315E	15 mm
PM0318E	18 mm
PM0322E	22 mm
PM0328E	28 mm

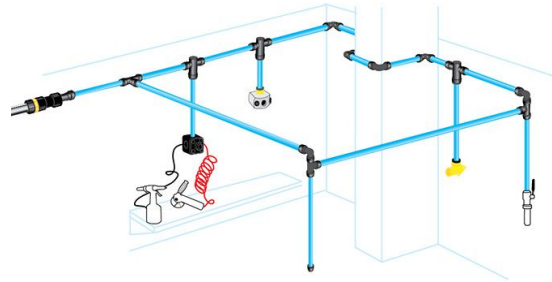

STEM ELBOW



BLANKING PLUG



PIPE CLIP - SPACERS



STRAIGHT ADAPTOR



Part Ref	Tube OD	Part Ref	Tube OD	Part Ref	Tube OD	Part Ref	Tube OD	Thread
PM221212E	12 mm	PM0812E	12 mm	PC15E	15 mm	PM011213E	12 mm	3/8"
PM221515E	15 mm	PM0815E	15 mm	PC18E	18 mm	PM0111214E	12 mm	1/2"
PM222222E	22 mm	PM0822E	22 mm	PC22E	22 mm	PM011514E	15 mm	1/2"
		PM0828E	28 mm	PC28E	28 mm	PM011814E	18 mm	1/2"
				PCSE	SPACER	PM012216E	22 mm	3/4"

STEM ADAPTOR



STEM REDUCER



BRASS STEM ADAPTOR



Part Ref	Tube OD	Thread	Part Ref	Stem OD	Tube OD	Part Ref	Tube OD	Thread
PM051213E	12 mm	3/8" <small>BSSP</small>	PM061512E	15 mm	12 mm	MM051504N	15 mm	1/2" BSPT
PM051214E	12 mm	1/2"	PM061815E	18 mm	15 mm	MM052206N	22 mm	3/4" BSPT
PM051513E	15 mm	3/8"	PM062215E	22 mm	15 mm	MM052818N	28 mm	1" BSSP
PM051514E	15 mm	1/2"	PM062218E	22 mm	18 mm			
PM051814E	18 mm	1/2"	PM062815E	28 mm	15 mm			
PM052214E	22 mm	1/2"	PM062822E	28 mm	22 mm			
PM052216E	22 mm	3/4"						

END STOP



Part Ref	Tube OD
PM4615E	15 mm
PM4622E	22 mm

OTHER ITEMS ARE AVAILABLE UPON REQUEST:

FLEXJOINTS, CUTTERS, FEMALE ADAPTORS AND SPARES



WATER TAP



WATER TAP CONVERTER



'U' BEND



Part Ref	Tube OD	Part Ref	Tube OD	Part Ref	Tube OD
PMTT22E	22mm	WTC28	15 mm	PMUB15E	15 mm

PUSH IN PLASTIC FITTINGS

STRAIGHT CONNECTOR



Part Ref	Tube OD
PFI1	5/32"
PFI3	3/16"
PFI4	1/4"
PFI5	5/16"
PFI6	3/8"
PFI8	1/2"

EQUAL ELBOW



Part Ref	Tube OD
PFI622	5/32"
PFI633	3/16"
PFI644	1/4"
PFI655	5/16"
PFI666	3/8"
PFI688	1/2"

EQUAL TEE



Part Ref	Tube OD
PFI922	5/32"
PFI933	3/16"
PFI944	1/4"
PFI955	5/16"
PFI966	3/8"
PFI988	1/2"

BLANKING PLUG



Part Ref	Tube OD
PFI1222	5/32"
PFI1233	3/16"
PFI1244	1/4"
PFI1255	5/16"
PFI1266	3/8"
PFI1288	1/2"

MALE STUD



Part Ref	Thread	Tube OD
BSPT		
PFI222	1/8"	5/32"
PFI223	1/8"	3/16"
PFI224	1/8"	1/4"
PFI225	1/8"	5/16"
PFI244	1/4"	1/4"
PFI245	1/4"	5/16"
PFI246	1/4"	3/8"
PFI265	3/8"	5/16"
PFI266	3/8"	3/8"
PFI268	3/8"	1/2"
PFI288	1/2"	1/2"

SWIVEL ELBOW



Part Ref	Thread	Tube OD
BSPT		
PFI442	1/8"	5/32"
PFI423	1/8"	3/16"
PFI424	1/8"	1/4"
PFI425	1/8"	5/16"
PFI442	1/4"	5/32"
PFI444	1/4"	1/4"
PFI445	1/4"	5/16"
PFI446	1/4"	3/8"
PFI465	3/8"	5/16"
PFI466	3/8"	3/8"
PFI468	3/8"	1/2"
PFI488	1/2"	1/2"

SWIVEL TEE



Part Ref	Thread	Tube OD
BSPT		
PFI522	1/8"	5/32"
PFI523	1/8"	3/16"
PFI524	1/8"	1/4"
PFI525	1/8"	5/16"
PFI542	1/4"	5/32"
PFI544	1/4"	1/4"
PFI545	1/4"	5/16"
PFI546	1/4"	3/8"
PFI565	3/8"	5/16"
PFI566	3/8"	3/8"
PFI568	3/8"	1/2"
PFI588	1/2"	1/2"



**NOT SUITABLE FOR
AIR BRAKES**

JG Speedfit®

PUSH IN PLASTIC FITTINGS

UNEQUAL CONNECTOR



Part Ref	Tube OD	Tube OD
PFI43	1/4"	3/16"
PFI53	5/16"	3/16"
PFI54	5/16"	1/4"
PFI64	3/8"	1/4"
PFI65	3/8"	5/16"
PFI86	1/2"	3/8"

UNEQUAL ELBOW



Part Ref	Tube OD	Tube OD
PFI652	5/16"	5/32"
PFI653	5/16"	3/16"
PFI654	5/16"	1/4"
PFI663	3/8"	3/16"
PFI664	3/8"	1/4"
PFI665	3/8"	5/16"
PFI686	1/2"	3/8"

EQUAL BULKHEAD



Part Ref	Thread	Tube OD
PFI21	1/4"	5/32"
PFI23	3/8"	3/16"
PFI24	3/8"	1/4"
PFI25	1/2"	5/16"
PFI26	1/2"	3/8"
PFI28	3/4"	1/2"

STUD STEM



Part Ref	Thread	Tube OD
<small>BSPT</small>		
PFI322	1/8"	5/32"
PFI323	1/8"	3/16"
PFI324	1/8"	1/4"
PFI325	1/8"	5/16"
PFI342	1/4"	5/32"
PFI344	1/4"	1/4"
PFI345	1/4"	5/16"
PFI346	1/4"	3/8"
PFI365	3/8"	5/16"
PFI366	3/8"	3/8"
PFI368	3/8"	1/2"
PFI388	1/2"	1/2"

STEM ELBOW



Part Ref	Stem OD	Tube OD
PFI822	5/32"	5/32"
PFI833	3/16"	3/16"
PFI844	1/4"	1/4"
PFI855	5/16"	5/16"
PFI863	3/8"	3/16"
PFI864	3/8"	1/4"
PFI865	3/8"	5/16"
PFI866	3/8"	3/8"
PFI888	1/2"	1/2"

STEM REDUCER



Part Ref	Stem OD	Tube OD
PFI153	3/16"	5/16"
PFI154	1/4"	5/16"
PFI165	5/16"	3/8"
PFI186	3/8"	1/2"

EQUAL DIVIDER



Part Ref	Tube OD	Tube OD
PFI1005	5/16"	5/16"
PFI1006	3/8"	3/8"

NOT SUITABLE FOR AIR BRAKES



TUBE CUTTERS



Ref: TC1

Spare Blade Ref: TCB1



Ref: TC2/G

SECTION

14

BRASS COMPRESSION

Imperial Fittings conform to EN12164, Part 1.
Metric Fittings conform to EN12165, Part 2.
All Imperial and Metric Fittings are suitable for use with: Brass, Copper, Nylon, Polythene, Bundy and POVC-coated copper tube.

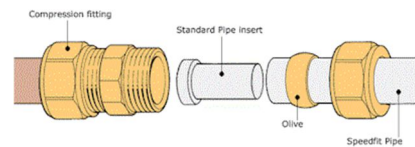

EQUAL JOINER



Part Ref	Tube Metric
1311	4 mm
1325	5 mm
1322	6 mm
1333	8 mm
1329	9 mm
1344	10 mm
1301	11 mm
1355	12 mm
1366	13 mm
1377	14 mm
1388	15 mm
1399	16 mm

Tube Imperial

1211	1/8"
1222	5/32"
1233	3/16"
1244	1/4"
1255	5/16"
1266	3/8"
1277	1/2"
1288	5/8"

EQUAL ELBOW



Part Ref	Tube Metric
1701	4 mm
1705	5 mm
1706	6 mm
1708	8 mm
1709	9 mm
1710	10 mm
1711	11 mm
1712	12 mm
1713	13 mm
1714	14 mm
1715	15 mm
1716	16 mm

Tube Imperial

1611	1/8"
1622	5/32"
1633	3/16"
1644	1/4"
1655	5/16"
1666	3/8"
1677	1/2"
1688	5/8"

EQUAL TEE



Part Ref	Tube Metric
1501	4 mm
1505	5 mm
1506	6 mm
1508	8 mm
1509	9 mm
1510	10 mm
1511	11 mm
1512	12 mm
1513	13 mm
1514	14 mm
1515	15 mm
1516	16 mm

Tube Imperial

1411	1/8"
1422	5/32"
1433	3/16"
1444	1/4"
1455	5/16"
1466	3/8"
1477	1/2"
1488	5/8"

BRASS COMPRESSION

MALE STUD

Part Ref	Thread	Tube Imperial
1811	1/8"	1/8"
1812	1/8"	5/32"
1813	1/8"	3/16"
1814	1/8"	1/4"
1815	1/8"	5/16"
1816	1/8"	3/8"
1841	1/4"	1/8"
1843	1/4"	3/16"
1844	1/4"	1/4"
1845	1/4"	5/16"
1846	1/4"	3/8"
1847	1/4"	1/2"
1864	3/8"	1/4"
1865	3/8"	5/16"
1866	3/8"	3/8"
1867	3/8"	1/2"
1874	1/2"	1/4"
1875	1/2"	5/16"
1876	1/2"	3/8"
1877	1/2"	1/2"



Tapered

Part Ref	Thread	Tube Metric
1911	1/8"	4 mm
1915	1/8"	5 mm
1916	1/8"	6 mm
1918	1/8"	8 mm
1910	1/8"	10 mm
1941	1/4"	4 mm
1945	1/4"	5 mm
1946	1/4"	6 mm
1948	1/4"	8 mm
1940	1/4"	10 mm
1942	1/4"	12 mm
1966	3/8"	6 mm
1968	3/8"	8 mm
1960	3/8"	10 mm
1962	3/8"	12 mm
1976	1/2"	6 mm
1978	1/2"	8 mm
1970	1/2"	10 mm
1972	1/2"	12 mm
1975	1/2"	15 mm
1979	1/2"	16 mm

BRASS ADAPTORS



Part Ref	Thread A	Thread B
1442	1/4"	1/8"
1462	3/8"	1/8"
1464	3/8"	1/4"
1472	1/2"	1/8"
1474	1/2"	1/4"
1476	1/2"	3/8"
1494	3/4"	1/4"
1496	3/4"	3/8"
1497	3/4"	1/2"
1519	1"	3/4"

BLANKING PLUGS



Part Ref	Thread Size
1402	1/8"
1404	1/4"
1406	3/8"
1407	1/2"
1409	3/4"
1410	1"

METRIC PLUGS

BP12B	M12 x 1.5
BP16B	M16 x 1.5
BP22B	M22 x 1.5



SOCKETS



Part Ref	Thread Size
1200	1/8"
1202	1/4"
1206	3/8"
1208	1/2"
1204	3/4"
1209	1"

BRASS COMPRESSION

UNIVERSAL STEPPED



Part Ref	Tube Metric
----------	-------------

1021	4 mm
1045	5 mm
1022	6 mm
1023	8 mm
1024	10 mm
1041	11 mm
1025	12 mm
1026	13 mm
1027	14 mm
1028	15 mm
1029	16 mm

Tube Imperial

1001	1/8"
1002	5/32"
1003	3/16"
1004	1/4"
1005	5/16"
1006	3/8"
1007	1/2"
1008	5/8"

CUTTING RINGS



Part Ref	Tube Metric
----------	-------------

O4B	4 mm
O6B	6 mm
O8B	8 mm
O9B	9 mm
O10B	10 mm
O12B	12 mm
O15B	15 mm
O16B	16 mm
O18B	18 mm

UNIVERSAL OLIVE



Part Ref	Tube Metric
----------	-------------

1112	4 mm
1113	5 mm
1114	6 mm
1115	8 mm
1116	10 mm
1117	12 mm
1119	15 mm

Tube Imperial

1086	1/8"
1087	3/16"
1088	1/4"
1089	5/16"
1090	3/8"
1091	1/2"

TUBE INSERTS



Part Ref	Tube Metric
----------	-------------

TI4	4 mm
TI6	6 mm
TI7	7 mm
TI7.5	7.5 mm
TI8	8 mm
TI9	9 mm
TI10	10 mm
TI11	11 mm
TI12	12 mm
TI14	14 mm

BARREL OLIVE



Part Ref	Tube Metric
----------	-------------

1031	4 mm
1032	6 mm
1033	8 mm
1034	10 mm
1035	12 mm
1036	13 mm
1037	14 mm
1038	15 mm
1039	16 mm

Tube Imperial

1011	1/8"
1012	5/32"
1013	3/16"
1014	1/4"
1015	5/16"
1016	3/8"
1017	1/2"
1018	5/8"

MALE - MALE ADAPTORS



Part Ref	Thread
----------	--------

BSPT	
MMA22B	1/8"
MMA44B	1/4"
MMA66B	3/8"
MMA88B	1/2"
MMA12B	3/4"
MMA16B	1"

BRASS COMPRESSION

STUD ELBOWS



Part Ref	Thread	Tube
1721	1/8"	1/8"
1722	1/8"	5/32"
1723	1/8"	3/16"
1724	1/8"	1/4"
1725	1/8"	5/16"
1743	1/4"	3/16"
1744	1/4"	1/4"
1745	1/4"	5/16"
1746	1/4"	3/8"
1747	1/4"	1/2"
1765	3/8"	5/16"
1766	3/8"	3/8"
1767	3/8"	1/2"
1776	1/2"	3/8"
1777	1/2"	1/2"

FEMALE STUDS



Part Ref	Thread	Tube
BSPP		
FSC24B	1/8"	4 mm
FSC26B	1/8"	6 mm
FSC46B	1/4"	6 mm
FSC28B	1/8"	8 mm
FSC48B	1/4"	8 mm
FSC68B	3/8"	8 mm
FSC410B	1/4"	10 mm
FSC610B	3/8"	10 mm
FSC810B	1/2"	10 mm
FSC612B	3/8"	12 mm
FSC812B	1/2"	12 mm
FSC815B	1/2"	15 mm

BLANKING CAPS



Part Ref	Tube Metric
BPC6	6 mm
BPC8	8 mm
BPC10	10 mm
BPC12	12 mm
BPC15	15 mm



ASSORTED BOXES

METRIC STRAIGHTS: BCSMA1

IMPERIAL STRAIGHTS: BCSIA1

1924	1/8"	4 mm
1925	1/8"	5 mm
1926	1/8"	6 mm
1928	1/8"	8 mm
1920	1/8"	10 mm
1929	1/4"	4 mm
1930	1/4"	5 mm
1931	1/4"	6 mm
1932	1/4"	8 mm
1933	1/4"	10 mm
1934	1/4"	12 mm
1935	3/8"	6 mm
1936	3/8"	8 mm
1937	3/8"	10 mm
1938	3/8"	12 mm
1951	1/2"	10 mm
1952	1/2"	12 mm
1953	1/2"	15 mm
1954	1/2"	16 mm



METRIC STEPPED OLIVES: 1020

IMPERIAL STEPPED OLIVES: 1010



SECTION

15



PCL is recognised as the global market leader in the design and manufacture of tyre inflation, air line accessories and compressed air products for industrial, petrol forecourt and automotive markets.

The products have been specially selected, designed and manufactured through years of experience to satisfy all your needs since 1938

VERTEX SLIM- LINE COUPLINGS



Part Ref	Male Thread
921	1/4"



Part Ref	Female Thread
920	1/4"



Part Ref	Female Thread
920HT	1/4"



Slimline couplings are specially designed to be less likely to accidentally disconnect when used in trailing hose applications in garages and workshops.

PCL Vertex Couplings are specially designed for TRAILING HOSE applications

STANDARD COUPLINGS



Part Ref	Male Thread
915	1/4"
916	3/8"
917	1/2"



Part Ref	Female Thread
918	1/4"
919	3/8"
914	1/2"



Part Ref	Hose ID
915HT	1/4"
916HT	3/8"
917HT	1/2"



SLIM-LINE & STANDARD BAYONETS



Part Ref	Male Thread
925	1/4"
926	3/8"



Part Ref	Female Thread
928	1/4"



Part Ref	Male Thread
924	1/4"

Standard Safety Adaptor

HOSE TO BAYONET



Part Ref	Hose ID
927	3/16"
929	1/4"
930	5/16"
931	3/8"

TWIN 'Y' CONNECTOR



Part Ref	Type
950	STANDARD
951	SLIM

FEMALE 'Y' ADAPTOR



Part Ref	Female Thread
922	1/4"

60 SERIES COUPLINGS & BAYONET FITTINGS

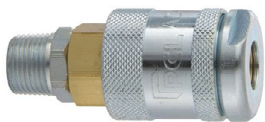

Part Ref	Male Thread
915/60	1/4"
916/60	3/8"
917/60	1/2"



Part Ref	Female Thread
918/60	1/4"
919/60	3/8"
935/60	1/2"



Standard Safety Adaptor

Part Ref	Male Thread
924/60	3/8"



Part Ref	Male Thread
925/60	1/4"
926/60	3/8"



Part Ref	Female Thread
928/60	1/4"
927/60	3/8"



Part Ref	Hose ID
930/60	5/16"
931/60	3/8"
940/60	1/2"



100 SERIES COUPLINGS & BAYONET FITTINGS



Part Ref	Male Thread
932	3/8"
933	1/2"



Part Ref	Female Thread
934	3/8"
935	1/2"



Standard Safety Adaptor

Part Ref	Male Thread
941	1/2"



Part Ref	Male Thread
936	3/8"
937	1/2"



Part Ref	Female Thread
938	3/8"



Part Ref	Hose ID
939	3/8"
940	1/2"

SAFE FLOW COUPLINGS



Part Ref	Male Thread
915/SC	1/4"
916/SC	3/8"
917/SC	1/2"



Part Ref	Female Thread
918/SC	1/4"
919/SC	3/8"
914/SC	1/2"



Part Ref	Hose ID
915HT/SC	1/4"
916HT/SC	3/8"
917HT/SC	1/2"

Safeflow represents maximum safety for a minimum outlay - safeflow Safety Couplings fits the standard PCL

Two stage self-venting release, elimination the dangers of hose whip



HOSE CONNECTOR



Part Ref	Male Thread
903	1/4"
904	5/16"
905	3/8"
906	1/2"

MALE ADAPTORS



Part Ref	Male Thread
HC6889	1/4"
HC2543-3/8	3/8"
HC2543-1/2	1/2"

MALE ADAPTORS



Part Ref	Male Thread
MMA44	1/4"
MMA66	3/8"
MMA88	1/2"

MINI COUPLINGS

The Mini Couplings are ideal for use in light engineering environments.

Lightweight and compact design - Manufactured in brass with chrome plate finish

COUPLINGS



Part Ref	Male Thread
----------	-------------

AC11AM	1/8"
AC11CM	1/4"



Part Ref	Female Thread
----------	---------------

AC11AF	1/8"
AC11CF	1/4"

HOSETAILED COUPLING



Part Ref	Hose ID
----------	---------

AC1106	6 mm
AC1108	8 mm
AC1109	9 mm

BULKHEAD COUPLING



Part Ref	Male Thread
----------	-------------

AC11BHAM	1/8"
AC11BHCM	1/4"

TUBE COUPLING



Part Ref	Tube OD
----------	---------

AC11RF6/4	6 mm
AC11RF8/6	8 mm

BULKHEAD TUBE COUPLING



Part Ref	Tube OD
----------	---------

AC11BH6/4	6 mm
AC11BH8/6	8 mm

ANTI KINK COUPLING



Part Ref	Tube OD
----------	---------

AC11AK6/4	6 mm
AC11AK8/6	8 mm



INTERCHANGABLE WITH

- Rectus 21
- Camozzi Mini
- Norgren 233
- Legris 21
- Schrader Mini
- Cejn 50

BAYONETS



Part Ref	Male Thread
----------	-------------

AA11AM	1/8"
AA11CM	1/4"

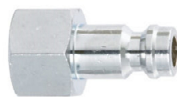

Part Ref	Female Thread
----------	---------------

AA11AF	1/8"
AA11CF	1/4"

HOSETAILED BAYONET



Part Ref	Hose ID
----------	---------

AA1104	4 mm
AA1106	6 mm
AA1109	9 mm

TUBE BAYONET



Part Ref	Tube OD
----------	---------

AC11AK6/4	6 mm
AC11AK8/6	8 mm

ANTI KINK BAYONET

Part Ref	Tube OD
----------	---------

AA11AK6/4	6 mm
AA11AK8/6	8 mm





HIGH FLOW XF RANGE

COUPLINGS



Part Ref	Male Thread
916/HF	3/8"
917/HF	1/2"



Part Ref	Female Thread
914/HF	1/4"
919/HF	3/8"
918/HF	1/2"

HOSETAILED COUPLING



Part Ref	Hose ID
917/HFHT	6 mm
915/HFHT	8 mm
919/HFHT	9 mm
916/HFHT	10 mm

BAYONET



Part Ref	Male Thread
924/HF	1/8"
925/HF	1/4"
926/HF	3/8"
937/HF	1/2"

HOSETAILED BAYONET



Part Ref	Hose ID
927/HF	4 mm
929/HF	6 mm
930/HF	8 mm
939/HF	10 mm
940/HF	13 mm
913/HF	9 mm

BAYONET

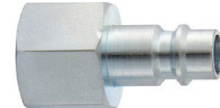

Part Ref	Female Thread
921/HF	1/8"
928/HF	1/4"
935/HF	3/8"
938/HF	1/2"

GRIP COUPLING



Part Ref	Male Thread
915/GRIP	1/4"
916/GRIP	3/8"
917/GRIP	1/2"

GRIP COUPLING



Part Ref	Female Thread
918/GRIP	1/4"
919/GRIP	3/8"
914/GRIP	1/2"



The XF Couplings offer excellent flow characteristics providing the workshop with increased airflow when required and enhanced tool efficiency.

XF Couplings, commonly referred to as Euro couplings, are designed and manufactured in the UK

- **High flow rate** - 130 cfm @ 100 psi
 - Offers enhanced tool efficiency
- Steel construction with corrosive resistant finish for longer life
 - Steel shoulder prevents accidental disconnection

INTERCHANGABLE WITH

Rectus 25/26 - Legris 25/26 - Cejn 320

Norgren 234/238 - Schrader InterCheck 35

HOSETAILES



Part Ref	Male Thread	Hose ID	
		IMPERIAL	METRIC mm
923	1/8"	3/16"	4.75
943	1/4"	3/16"	4.75
944	1/4"	1/4"	6.35
945	1/4"	5/16"	7.90
946	1/4"	3/8"	9.50
947	3/8"	1/2"	12.70
964	3/8"	1/4"	6.35
965	3/8"	5/16"	7.90
966	3/8"	3/8"	9.50
967	3/8"	1/2"	12.70
976	1/2"	3/8"	9.50
977	1/2"	1/2"	12.70

WORKSHOP ACCESSORIES

Part Ref: 970

Spec:
 Maximum Supply Pressure:
 10 bar / 140 psi
 Air Flow: 270 l/min / 9.3 cfm
 Connection: 1/4" female
 Temperature Range:
 0 to 80 °C
 Grip Style: Pistol
 Nozzle Style: Safety



Part Ref: 971

Spec:
 Maximum Supply Pressure:
 10 bar / 140 psi
 Connection: 1/4" Female
 Air Flow: 270 l/min / 9.3 cfm
 Temperature Range:
 0 to 80 °C
 Grip Style: Pistol
 Nozzle Style: 9" Extension



Replacement
 Nozzles
 Available

Part Ref: 954 (Conical) 955 (Safety)

Spec:
 Maximum Supply Pressure:
 14 bar / 200 psi
 Connection: 1/4" Female
 Air Flow: 148 l/min / 5.2 cfm
 Temperature Range:
 -20°C to 80°C
 Grip Style: Palm



Part Ref: 956

Spec:
 Maximum Supply Pressure:
 10 bar / 140 psi
 Connection: 1/4" Female
 Air Flow: 320 l/min / 11.2 cfm
 Temperature Range:
 0 to 80 °C
 Grip Style: Pistol
 Nozzle Style: Conical & Safety



This Safety Aircurtain Blowgun is equipped with a safety nozzle, which not only meets requirements on noise and safety, it also provides extremely high blowing force.

Part Ref: 971S Aircurtain

Spec:
 Maximum Supply Pressure:
 16 bar / 232 psi
 Connection: 1/4" Female
 Temperature Range:
 -10°C to 80°C
 Grip Style: Pistol
 Nozzle Style: Low Noise Safety



Part Ref: 970S Aircurtain

Spec: @ 8 Bar
 Maximum Supply Pressure:
 10 bar / 140 psi
 Connection: 1/4" Female
 Air Flow : 580 l/min / 20.5 cfm
 Noise: 78.0 db
 Temperature Range:
 -10°C to 80°C





Part Ref: 910

Spec:
 Maximum Working Pressure:
 200 psi / 14 bar
 Hose Inside Diameter: 6mm
 Hose Outside Diameter: 8mm
 Working Length: 25FT



TYRE VALVE CONNECTORS

Suitable for use in tyreshops

A **Closed** End connector is used when air is supplied directly from a main air line (i.e. compressor or air receiver). A non-return valve unseats on connection to the tyre's valve allowing air to flow into the tyre.



An **Open** End connector is used with the MK3 Tyre Inflator, PCL wall gauges and PCL portable gauges. This connector has a pin which unseats the tyre's valve when in use.

Part Ref	End	Hose ID
992	OPEN	6.35 mm - 1/4"
993	CLOSED	6.35 mm - 1/4"
994	OPEN	4.75 mm - 3/16"
995	CLOSED	4.75 mm - 3/16"

Part Ref	Type	Hose ID / Thread
CH2K01	STRAIGHT	7.9 mm - 5/16"
CH2H01	STRAIGHT	6.35 mm - 1/4"
CH2A01	STRAIGHT	1/4" Inlet
CH4K01	ANGLED	7.9 mm - 5/16"
CH4H01	ANGLED	6.35 mm - 1/4"
CH4A01	ANGLED	1/4" Inlet

Alloy/steel wheels have got bigger with intricate designs making the valves more difficult to reach with the human hand. The new range now consists of standard straight as well as 90-degree connectors for those difficult to reach valves, with both hose tail fitting and female threaded versions available.

Manufactured using the finest zinc alloy, aluminium and brass, the Air Connector boasts a vice like grip and easy operation with a simple but effective thumb push button which quickly releases the tyre valve, reducing non-value added time

- Once the PCL Air Connector is on, it stays on!
Does not bleed air
- Simple but effective thumb push button - **quickly releases the tyre valve, reducing non-value added time**
- Simply turn clockwise to achieve even more grip
 - **Highly reliable**
- This open end connector is suitable for use with the MK4 Tyre Inflator, PCL wall gauges and PCL portable gauges
Suitable for use in garages, workshops and tyre shops



Part Ref: 998 (3/16")
998/1(1/4")



The Euro Style Clip-on Open End Connector is suitable for use in tyreshops.



TYRE VALVE CONNECTORS



It is important when purchasing connectors to specify whether you require a closed or open end type

A **Closed End** connector is used when air is supplied directly from a main air line (i.e. compressor or air receiver). A non-return valve unseats on connection to the tyre's valve allowing air to flow into the tyre. The handles on these connectors are **red** in colour.

An **Open End** connector is used with MK4 Tyre Inflator, PCL wall gauges and PCL portable gauges. This connector has a pin which unseats the tyre's valve when in use. The handles on these connectors are **black** in colour.

Twin hold-on



Part Ref: 988 (OPEN)
989(CLOSED)

Spec:
Connection: 1/4" Female
Short Stem Available.
Suitable for inflation of twin tyres.

Twin clip-on



Part Ref: 990 (OPEN)
991(CLOSED)

Spec:
Connection: 1/4" Female
Suitable for inflation of twin tyres.



Part Ref: ALGTS (OPEN - TWIN HOLD ON)

- Accuracy Meets: EC 86/217 Compliant with EN12645:2014
 - Reading Accuracy: 0.1 bar / 2 psi
- Maximum Inlet Pressure: 13.8 bar / 200 psi
- Inflation Flow: 500 l/min / 18 cfm
 - 21" Hose
- Longer lengths and ends available
- Operating Temperature: -25 to 55 °C

Part Ref: ALGTS/D (OPEN - TWIN HOLD ON)

- Dimensions (L x W): 210 mm x 50 mm / 8.27 in x 1.9 in
 - Weight: 495 g / 1.09 lbs
- LCD screen: 28 mm x 20 mm / 1.1 in x 0.79 in
 - Digit height: 8 mm / 0.31 in
- Operating Temperature: -15 to 55°C / 5 to 131°F
- Storage temperature range: -30 to 80°C / -22 to 176°F
 - Reading Accuracy: 0.1 psi / 0.01 bar / 1 kPa
- Max Inflation Pressure: 250 psi / 17.2 bar / 1723 kPa
- Max Inlet Pressure: 260 psi / 18.0 bar / 1795 kPa
- Inflation Flow (@ 190 psi / 13 bar): 500 l/min / 18 CFM
 - Battery Type: 2 x AAA (supplied)





HOSE ASSEMBLIES

- A variety of different lengths and connectors available to your requirements
- A quick, easy and simple solution to hose replacement



**HOSE SOLD SEPERATLEY ALSO IN SECTION 16
CLIPS TO SUIT IN SECTION 8**

HOSE REELS



Part Ref: HRA1B03

- Maximum Working Pressure: 200 psi / 13.8 bar
 - Hose Length: 15 mtr
 - Hose Inside Diameter: 3/8 in / 10 mm
 - Inlet & Outlet Thread: 1/4"

**VARIETY OF
HOSE REELS
AVAILABLE**



TYRE PRESSURE GAUGES



Part Ref: 969 Tyre Depth Gauge - Measures tread size 1 to 26 mm (1.6mm Mark)

Part Ref: 981 Tyre Depth Gauge - Twin Head - 10 to 120 psi - 0.8 to 8.2 bar



Part Ref: 983 Tyre Depth Gauge - InLine Head - 6 to 50 psi - 0.5 to 3.4 bar

**Part Ref: 986 Tyre Depth Gauge - Twin Head - Heavy Duty - Rubber Handled
10 to 160 psi - 0.8 to 11 bar**





Part Ref: MC / 921

Truck - Trailer Male 'C' Outlet

Standard PCL Connection for air options



Clamps and clips available in section 8
Hose to suit available in section 16

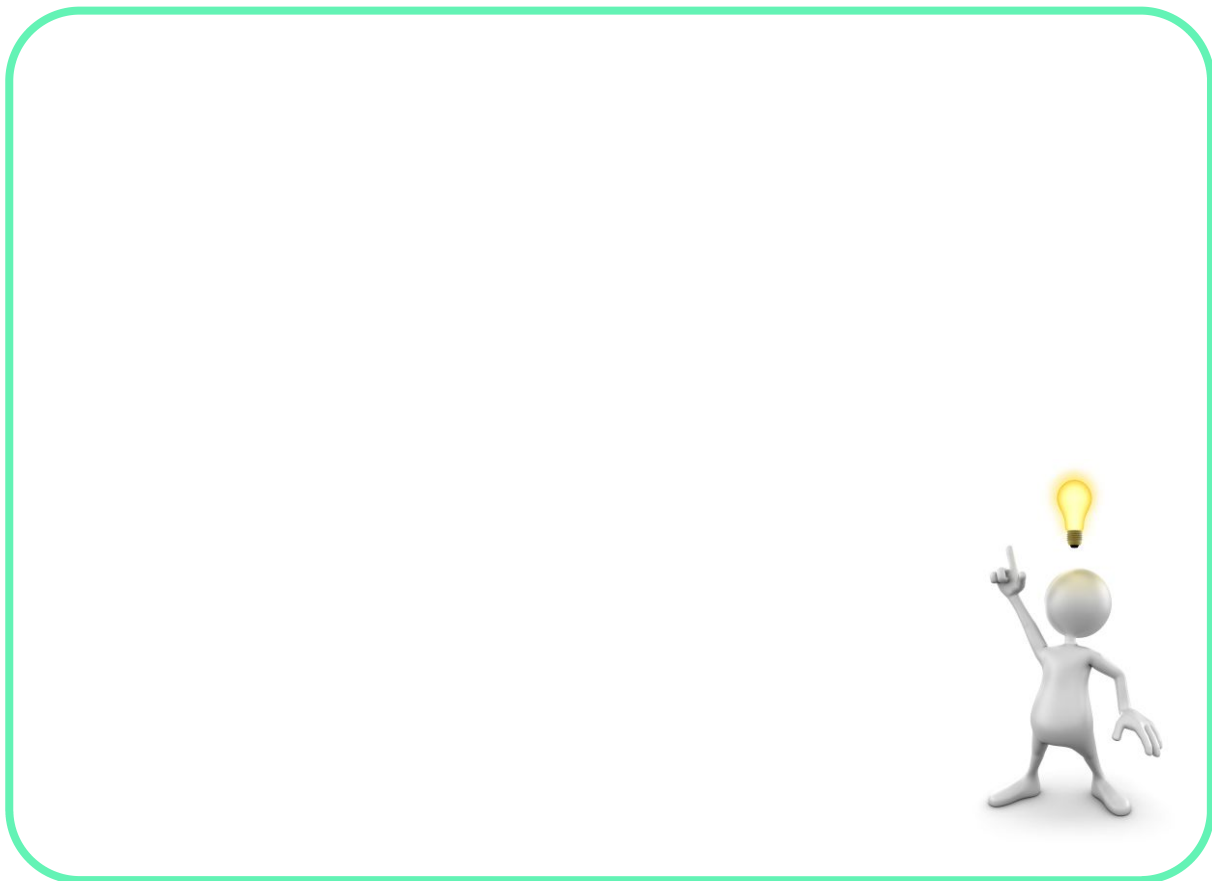

SECTION

16

HOSE & TUBING



PVC TUBING

- Glass clear transparency for easy visibility.
- Excellent abrasion and corrosion properties for increased durability.
- Good flexibility for ease of use.
- Manufactured from cadmium and silicone-free materials using a special low toxic, odourless PVC formulation that can reduce the taint of drinking water.
- EU No.10/2011 compliant for food contact applications.
 - RoHS 3 compliant.
- Suitable for use with alcohol, petrol, oils, greases and solvents.
 - Highly resistant to a wide range of acids and alkalis.
 - Service temperature = -15°C to + 60°C.
- NSF51 + NSF61 approved for the transfer of drinking water.

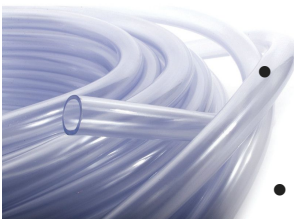

Part Ref	Hose ID (Imperial)	Hose ID (Metric)	Wall Thickness
----------	--------------------	------------------	----------------

PVC1	1/8"	3 mm	1.5 mm
PVC3	3/16"	5 mm	1.5 mm
PVC4	1/4"	6 mm	1.5 mm
PVC5	5/16"	8 mm	1.5 mm
PVC6	3/8"	10 mm	1.5 mm



Part Ref	Hose ID (Imperial)	Hose ID (Metric)	Wall Thickness
----------	--------------------	------------------	----------------

PVC8	1/2"	12 mm	1.5 mm
PVC10	5/8"	16 mm	1.5 mm
PVC12	3/4"	19 mm	1.5 mm
PVC16	1"	25 mm	3 mm

Part Ref: PVCWI

6 mm OD x 4 mm ID Windscreen Washer Tube

BRAIDED PVC TUBING - 30 MTR COILS



- Excellent glass clear transparency for clear visibility.
- Good flexibility for ease of use.
- Resistant to a wide range of chemicals including many acids / alkalis.
- Abrasion resistant. Thicker wall gives medium to heavy duty durability for improved resistance to abrasion.
- Specially selected high tensile Polyester fiber reinforcement used at the optimum braid angle of 54° 44'(54.73°) creates an effective and balanced pressure hose.
- EU No. 10/2011 compliant for food contact applications.
- RoHS 3 compliant.
- Manufactured from cadmium and silicone-free materials, using a specialist PVC that can reduce the taint of drinking water.
- Manufactured in accordance with ISO 5774.
- 4:1 safety factor.
- NSF51 + NSF61 approved for the transfer of drinking water.

Part Ref	Hose ID (Imperial)	Hose ID (Metric)	Tube OD
PVC1N	1/8"	3 mm	8 mm
PVC3N	3/16"	5 mm	10 mm
PVC4N	1/4"	6.3 mm	10.5 mm
PVC5N	5/16"	8 mm	12 mm
PVC6N	3/8"	10 mm	14 mm
PVC8N	1/2"	12.5 mm	17.5 mm



Part Ref	Hose ID (Imperial)	Hose ID (Metric)	Tube OD
PVC10N	5/8"	16 mm	20.25 mm
PVC12N	3/4"	19 mm	24 mm
PVC16N	1"	25 mm	31 mm
PVC20N	1 1/4"	32 mm	42 mm
PVC24N	1 1/2"	38 mm	48 mm
PVC32N	2"	50 mm	60 mm

FUEL LINE HOSE



SPECIFICATION: SAEJ30R9
APPLICATION: For fuel injection systems
TUBE: NBR / SBR Blended
REINFORCEMENT: High tensile, synthetic fibres
COVER: Polyester Yarn
TEMPERATURE RANGE: -34°C to +135°C
SAFETY FACTOR: 4:1

Part Ref	Hose ID (Imperial)	Coil Length
FLH1/20	1/8"	20 Mtr
FLH3/10	3/16"	10 Mtr
FLH4/10	1/4"	10 Mtr
FLH5/10	5/16"	10 Mtr
FLH6/10	3/8"	10 Mtr
FLH8/10	1/2"	10 Mtr
FLH10/10	5/8"	10 Mtr
FLH12/10	3/4"	10 Mtr
FLH14/10	7/8"	10 Mtr

HEATER HOSE



SPECIFICATION: SAEJ20R3
APPLICATION: For conveyance of hot water predominantly in vehicles
TUBE: EPDM
REINFORCEMENT: Polyester Yarn
COVER: EPDM (Smooth Cover)
TEMPERATURE RANGE: -40°C to +125°C
SAFETY FACTOR: 3:1

Part Ref	Hose ID (Imperial)	Coil Length
HH4/10	1/4"	10 Mtr
HH6/10	3/8"	10 Mtr
HH8/10	1/2"	10 Mtr
HH10/10	5/8"	10 Mtr
HH12/10	3/4"	10 Mtr
HH14/10	7/8"	10 Mtr
HH16/10	1"	10 Mtr

If you require a 20 mtr Length replace the 10 with a 20 eg: HH6/20

AIR LINE HOSE



APPLICATION: For general workshop use and with compressors.

TUBE: Black thermo rubber compound

REINFORCEMENT: Polyester Yarn

COVER: Black, abrasion and weather resistant thermo rubber compound with yellow stripe

TEMPERATURE RANGE: -10°C to +60°C

SAFETY FACTOR: 3:1

BRANDING: W = 300psi 20 bar

Part Ref	Hose ID (Imperial)	Coil Length
ALH4/10	1/4"	10 Mtr
ALH4/15	1/4"	15 Mtr
ALH4/100	1/4"	100 Mtr
ALH5/10	5/16"	10 Mtr
ALH5/15	5/16"	15 Mtr
ALH5/100	5/16"	100 Mtr
ALH6/10	3/8"	10 Mtr
ALH6/15	3/8"	15 Mtr
ALH6/100	3/8"	100 Mtr
ALH8/15	1/2"	15 Mtr



Workshop accessories and fittings are in Section 15 - PCL

Clips & Clamps Section 8

AIR LINE HOSE - PRE MADE COILS



Part Ref: TPAHA918

Air Line Extension from
Test Point Adaptor

15 Metre

M16 Female Test point
adaptor (TPA2)
x
Standard Coupling (918)



Part Ref: TIHA

Tyre Inflator Hose
assembly

M16 Female Test
point adaptor (TPA2)
x
Hold on Inflator
(989)

15 Mtr



Part Ref: PCLHW

Tool Hose Whip

1 Metre

1/4" Thread (944)
x
Standard Bayonet
(929)



Part Ref: PCLEXT

Air Line Extensions

15 Metre

Standard Bayonet (929)
x
Standard Coupling (918)

Air Lines can be made to your specific requirements in house using any combinations of couplings or fittings - Please enquire



AIR BRAKE HOSE

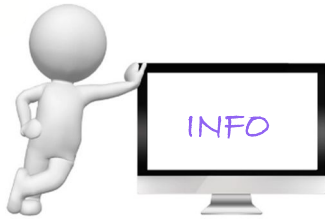

SPECIFICATION: SAEJ1402 TYPE A
APPLICATION: For use on automotive air brake applications
TUBE: Black EPDM
REINFORCEMENT: Polyester Yarn
COVER: EPDM
TEMPERATURE RANGE: -40°C to +100°C
SAFETY FACTOR: 3:1
BRANDING: W=BSAU 110A/A SAEJ1402/A



Part Ref	Hose ID (Imperial)	Coil Length
ABH6/10	3/8"	10 Mtr
ABH6/15	3/8"	15 Mtr
ABH6/60	3/8"	60 ft (18.3 Mtr)
ABH6/100	3/8"	100 Mtr
ABH7/10	1/2"	10 Mtr
ABH7/15	1/2"	15 Mtr
ABH7/60	1/2"	60 ft (18.3 Mtr)
ABH7/100	1/2"	100 mtr
ABH8/10	5/8"	10 Mtr

Part Ref	Hose ID (Metric)	Coil Length
ABH13/10	13 mm	10 Mtr
ABH13/15	13 mm	15 Mtr
ABH13/20	13 mm	20 Mtr
ABH13/50	13 mm	50 Mtr

Application: Compressed Air - Vehicles

Working Temperature: -40°C to 70°C

Inside: EPDM **Colour:** Black **Reinforcement:** Polyester

Outside: EPDM **Standards:** DIN 74310: 1976

HOSE ASSEMBLIES (Standard Lengths)



Hose ID	M16 x 1.5 mm Hosetails	1/4" Hosetails	Hose Length
3/8"	BHA216	BHA24	2 ft
3/8"	BHA2616	BHA264	2.5 ft
3/8"	BHA316	BHA34	3 ft
3/8"	BHA3616	BHA364	3.5 ft
3/8"	BHA416	BHA44	4 ft
3/8"	BHA4616	BHA464	4.5 ft
3/8"	BHA516	BHA54	5 ft
3/8"	BHA5616	BHA564	5.5 ft
3/8"	BHA616	BHA64	6 ft
13 mm	BHA133	-	3 ft
13 mm	BHA134	-	4 ft
13 mm	BHJA135	-	5 ft
13 mm	BHA136	-	6 ft

FERRULES



Part Ref	Hose ID
F4	1/4"
F6	3/8"
F7	1/2"
F13	13 mm



Hosetails - Section 2

Hose assemblies can be made to any requirement



CONDUIT

SELF EXTINGUISHING

30 Mtr Coils

Part Ref	Hose ID
----------	---------

CON10	10 mm
CON20	20 mm
CON25	25 mm
CON40	40 mm



SPIRAL WRAP



Part Ref	Hose ID	Coil Length (M)
----------	---------	-----------------

ARM6	6 mm	100
ARM10	10 mm	50
ARM16	16 mm	50
ARM20	20 mm	50
ARM22	22 mm	25
ARM26	26 mm	25
ARM30	30 mm	25



SECTION 8 INCLUDES



CUTTERS & BLADES

Part Ref

TC1

CUTS UP TO
18MM OD



Part Ref

TCB1

CUTS UP TO
28 MM OD

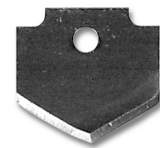

Part Ref

TC2

CUTS UP TO
28 MM OD



Part Ref

TCB2



Part Ref

TC2/G

CUTS UP TO 22 MM



Part Ref

TC3

CUTS UP TO 12 MM





SECTION

17

RAUFOSS ABC SYSTEM

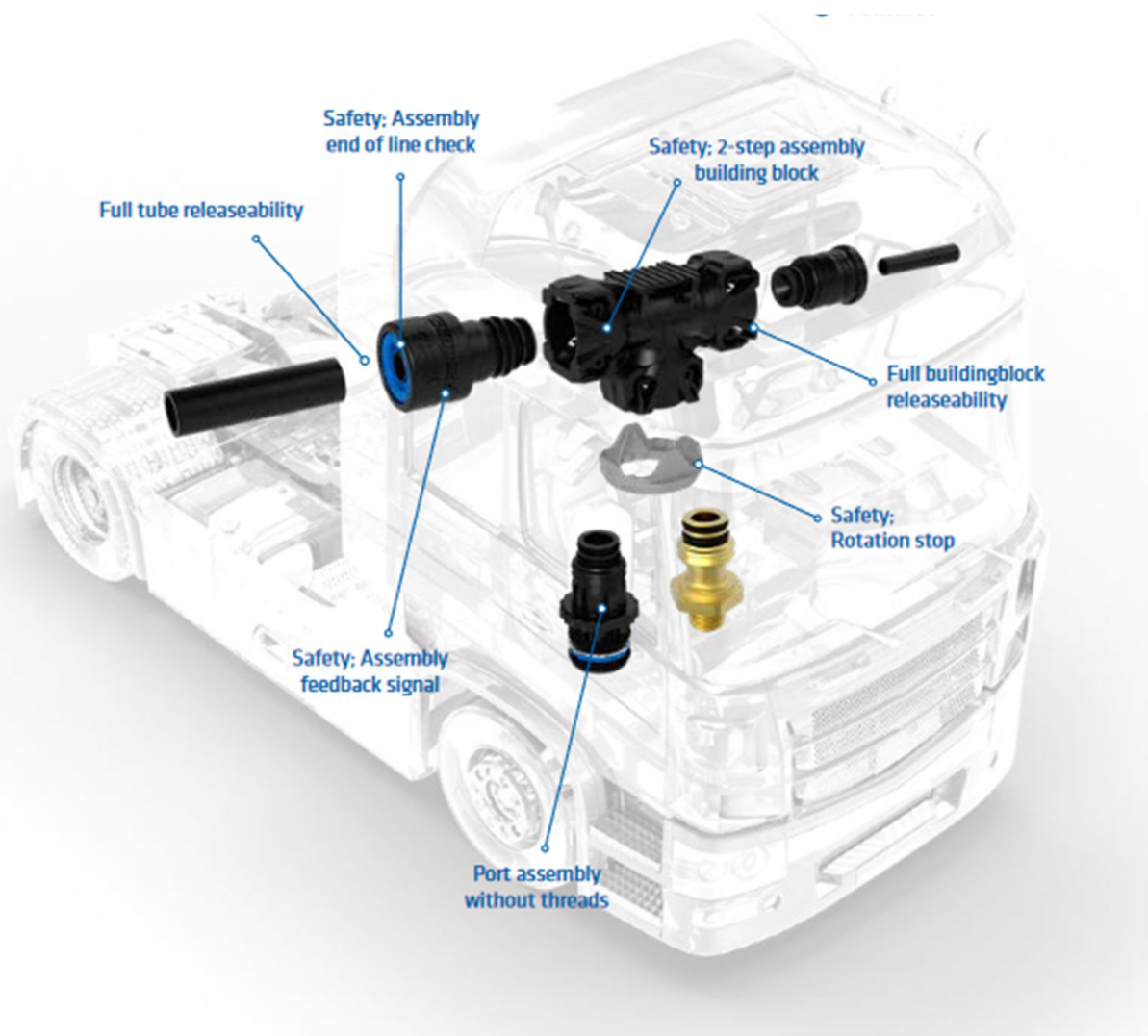

RAUFOSS ABC SYSTEM



Swivel Type - Building Block Size	To Suit Tube Sizes	Cap Colour	Swivel Width 'mm'
Small	6x1mm - 8x1mm	White	15
Regular	6x1mm To 12x1.5mm	Green	17
Heavy Duty	12x1.5mm - 14x2mm - 15x1.5mm - 16 x 2mm	Blue	20

PLEASE NOTE PORT SIZES COME IN SMALL, REGULAR & HEAVY DUTY

THREADLESS COUPLINGS



Part Ref	Type	Tube
		mm
902 04 004	Small	4x1
902 06 004	Small	6x1
902 08 004	Small	8x1
902 06 005	Regular	6x1
902 08 005	Regular	8x1
902 10 005	Regular	10x1
902 10 105	Regular	10x125
901 10 205	Regular	10x1.5
902 12 005	Regular	12x1.5
902 95 305	Regular	3/8"
902 12 705	Regular	1/2"
902 12 006	HD	12x1.5
902 14 006	HD	14x2
902 15 006	HD	15x1.5
902 16 006	HD	16x2

INTERGRAL PUSH IN ELBOW



Part Ref	Type	Tube
		mm
903 06 004	Small	6x1
903 08 004	Small	8x1
903 06 005	Regular	6x1
903 08 005	Regular	8x1
903 10 005	Regular	10x1
903 10 105	Regular	10x125
903 10 205	Regular	10x1.5
903 12 205	Regular	12x1.5
903 15 006	HD	15x1.5
903 16 006	HD	16x2

TUBE CONNECTOR



Part Ref	Tube
	mm
905 06 006	6x1
905 08 008	8x1
905 10 010	10x1
905 10 110	10x1.25
905 10 210	10x1.5
905 12 012	12x1.5
905 15 015	15x1.5
905 16 016	16x2

SWIVEL MALE STUD



Part Ref	Type	Thread	Part Ref	Type	Thread
931 40 010	Small	M10 x 1	931 50 014	Regular	M14 x 1.5
931 40 012	Small	M12 x 1.5	931 50 016	Regular	M16 x 1.5
931 40 014	Small	M14 x 1.5	931 50 022	Regular	M22 x 1.5
931 40 016	Small	M16 x 1.5	931 60 016	HD	M16 x 1.5
931 50 010	Regular	M10 x 1	931 60 022	HD	M22 x 1.5
931 50 012	Regular	M12 x 1.5	931 60 026	HD	M26 x 1.5

THREADLESS TEST POINT

Part Ref	Type
960 50 000	Regular



SWIVEL BULKHEADS

Part Ref	Type	Thread
933 52 418	Reg	M18 x 1.5



Part Ref	Type	Male Thread	Female Thread
933 51 622	Regular	M22 x 1.5	M16 x 1.5

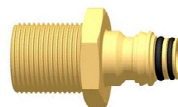

Part Ref	Type	Thread 1	Thread 2
933 52 216	Regular	M16 x 1.5	M22 x 1.5
933 52 222	Regular	M22 x 1.5	M22 x 1.5

**90°
Elbow**



Part Ref	Type
920 50 090	Regular
920 60 090	HD

**'F' Type
Elbow**

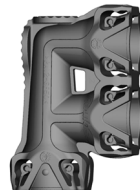

Part Ref	Type
920 40 015	Small
920 50 015	Regular

**Straight
Union**



Part Ref	Type
961 50 205	Regular

**45°
Elbow**



Part Ref	Type
920 50 045	Regular

**'Y'
Type
Union**

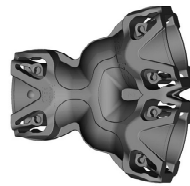

Part Ref	Type
920 50 030	Regular

**4 Way
Union**

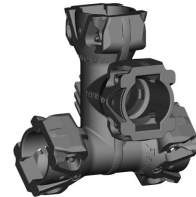

Part Ref	Type
920 50 061	Regular

**4 Way
Cross
Union**



Part Ref	Type
920 50 070	Regular

**3 Way
Elbow**

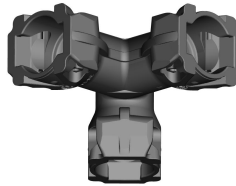

Part Ref	Type
920 52 060	Regular

**Tee
Coupling**



Part Ref	Type
920 40 010	Small
920 50 010	Regular

Male Union Adaptor



Part Ref	Type 1	Type 2
965 50 005	Regular	Regular
965 50 006	Regular	HD

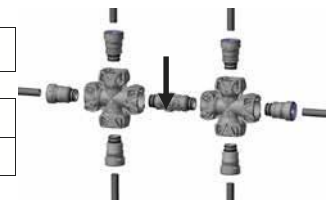

ROTOLOCK - POSITION LOCK



Part Ref	Type	Spanner Size
964 42 022	Small	22 mm
964 52 018	Regular	18 mm
964 50 022	Regular	22 mm
964 52 028	Regular	28 mm

RELEASE TOOLS & PLIERS

Part Ref	Tube
RT6	6 mm
RT8	8 mm
RT10	10 mm
RT12	12 mm
RT14	14 mm
RT15	15 mm
RT16	16 mm

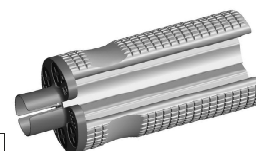

Part Ref	Tube
RT6M	6 mm
RT8M	8 mm
RT10M	10 mm
RT12M	12 mm
RT15M	15 mm
RT16M	16 mm



Part Ref

RP1



RAUFOSS ABC SYSTEM ASSORTED BOX (Regular 36 Piece)

Part Ref: **RAUFAB**

Box Contents:

	902 10 105 x 2	931 50 022 x 3	
	902 12 005 x 2	920 50 010 x 2	RT6 x 1
903 06 005 x 2	903 12 205 x 2	931 50 012 x 2	950 50 090 x 2
			RT8 x 1
903 08 005 x 2	902 06 005 x 2	931 50 014 x 2	960 50 000 x 1
			RT10 x 1
903 10 105 x 2	902 08 005 x 2	931 50 016 x 3	RP1 (Pliers) x 1
			RT12 x 1

RAUFOSS ABC SYSTEM ASSORTED BOX (Regular - HD 100 Piece)

Part Ref: **RAUFAB/2**

Box Contents:

931 500 12 x 3	RS800722 x 3	
931 500 14 x 2	964 520 18 x 1	RT6 x 2
931 500 16 x 5	964 500 22 x 1	RT8 x 2
931 500 22 x 3	964 500 20 x 2	RT12 x 2
RS800212 x 3	964 500 28 x 2	920 500 10 x 3
RS800216 x 3	962 100 08 x 3	920 500 30 x 3
RS800312 x 5	962 100 12 x 3	961 501 06 x 2
RS800316 x 3	902 060 05 x 2	920 600 90 x 2
RS800322 x 3	902 080 05 x 5	920 600 10 x 1
RS800516 x 5	902 120 05 x 5	931 600 16 x 2
RS800522 x 3	902 160 06 x 2	931 600 22 x 2
RS800716 x 2	931 502 05 x 5	920 500 90 x 5



**PUSH
IN
PLUG**



PORT REDUCER



Part Ref	Tube
962 10 006	6 mm
962 10 008	8 mm
962 10 010	10 mm
962 10 012	12 mm
962 10 015	15 mm
962 10 016	16 mm

Part Ref	Port
961 501 06	HD - Regular

SECTION



18



COUPLINGS - VALVES - TEST EQUIPMENT



BRITISH STANDARD BSAU138b:2000 COUPLINGS



- This standard combines the components of the older standard. Reducing the need for assembly and eliminating potential assembly errors or leakage.
- All couplings have colour coded labels - yellow for the service line and red for the emergency line.
- The outer sleeves of the female couplings are anodised aluminium and use the same colour code.
 - All steel parts are Zinc-Nickel plated to 12 micron and black passivated. This typically gives protection against at least 350 hours of salt spray. This is well in excess of the 96 hours required by BS AU 138b:2000.
 - Metric Thread is indicated by a groove on the hexagon.

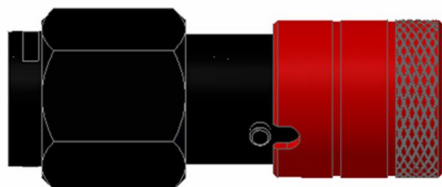
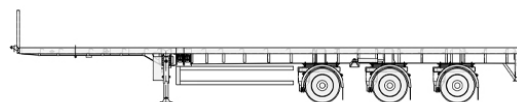
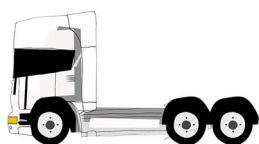

Part Ref	Thread
SSVCA16FH	M16 x 1.5 mm
SSVCA22FH	M22 x 1.5 mm
SSVCA7FH	1/2" BSP

Part Ref	Thread
MC16FH	M16 x 1.5 mm
MC22FH	M22 x 1.5 mm
MC7FH	1/2" BSP

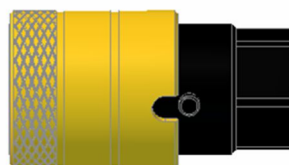

Part Ref	Thread
SSV16FH	M16 x 1.5 mm
SSV22FH	M22 x 1.5 mm
SSV7FH	1/2" BSP

Part Ref	Thread
FCOV16FH	M16 x 1.5 mm
FCOV22FH	M22 x 1.5 mm
FCOV7FH	1/2" BSP

COUPLINGS

TRUCK - TRACTOR



TRAILER

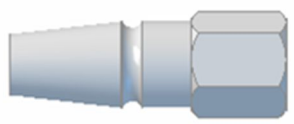
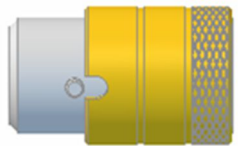
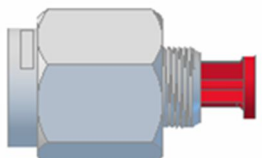
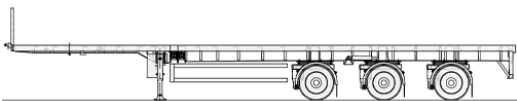

Part Ref	Thread
SSVCA71R	1/2" BSP
SSVCA221R	M22 x 1.5 mm



Part Ref	Thread
FC71R	1/2" BSP
FC221R	M22 x 1.5 mm



Part Ref	Thread
MC71R	1/2" BSP
MC221R	M22 x 1.5 mm

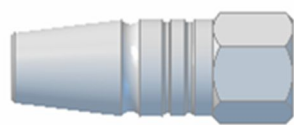
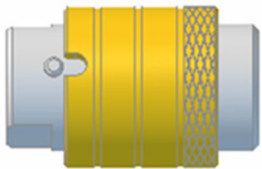
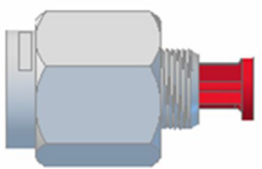

Part Ref	Thread
SSVCA71R	1/2" BSP
SSVCA221R	M22 x 1.5 mm



Part Ref	Thread
FCA71R	1/2" BSP
FCA221R	M22 x 1.5 mm



Part Ref	Thread
MCA71R	1/2" BSP
MCA221R	M22 x 1.5 mm

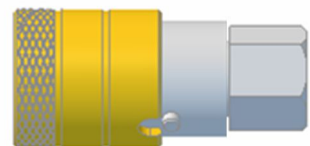
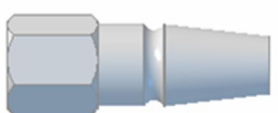
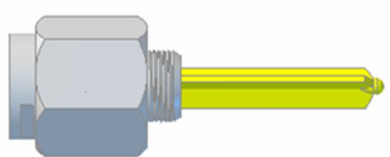

Part Ref	Thread
SSV71R	1/2" BSP
SSV221R	M22 x 1.5 mm



Part Ref	Thread
MC71R	1/2" BSP
MC221R	M22 x 1.5 mm



Part Ref	Thread
FCOV71R	1/2" BSP
FCOV221R	M22 x 1.5 mm



OR

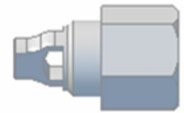
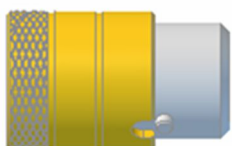
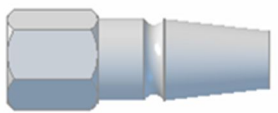
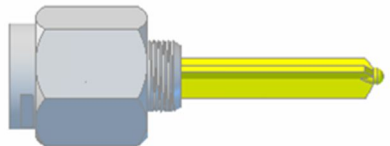

Part Ref	Thread
SSV71R	1/2" BSP
SSV221R	M22 x 1.5 mm



Part Ref	Thread
MC71R	1/2" BSP
MC221R	M22 x 1.5 mm



Part Ref	Thread
FC71R	1/2" BSP
FC221R	M22 x 1.5 mm



Part Ref	Thread
OV71R	1/2" BSP
OV221R	M22 x 1.5 mm

COUPLING LOCKS



MALE AIR LINE LOCK - Part Ref: **ABCCL2**

- The C-lock locks over the male coupling, preventing the trailer from being coupled up.
- The lock sleeve is long enough to cover the male coupling preventing it from being unscrewed from the trailer.
- Each lock is supplied with two keys, which are tucked inside a plastic cap for transit.
- Compact, rugged and simple to operate.
- To fit - Remove the key and push the lock onto the male.
- Locks can be keyed to individual numbers or alternatively batches can be ordered to the same key number (a number of locks operating to the same key).



Lock complete with VOR Sleeve **Part Ref: ABCCL2VOR**

Self Adhesive VOR Sleeve **Part Ref: VORL**

Spare Keys

Part Ref:
ABCCLCSK



VOR Disc

Part Ref: VORD



PALM LOCK - Part Ref: **ABCPL1**

- This is a lock to cover the palm coupling and prevent the accidental coupling of a trailer.
 - The yellow VOR disc also fits this model
- To fit - Remove the key and fit the lock over the coupling then press in the lock.
- To remove - Unlock with the key and slip the lock off the palm coupling.
- Sets of locks operated with the same key may be purchased. This key may also be used on the standard Lock.
- Locks benefit from an occasional application of mineral oil to the inside

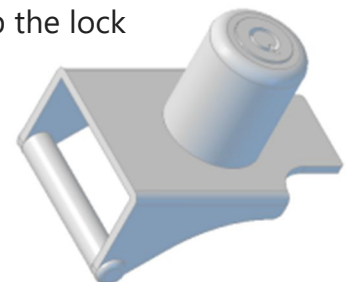

DUMMY COUPLINGS & CLIPS

Part Ref: FCMCDUM (Paired)

- Secure stowage locations for Couplings.
- Reduce damage to air coils.
- Compact in size.
- Chains and clips to suit available.
- Female has a drainage hole.

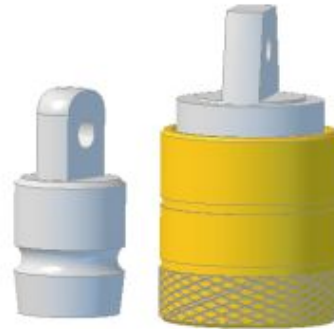

Part Ref:
MCDUM
(Male)

Part Ref:
FCDUM
(Female)

PVC Male Protective Cover
Part Ref: MC1



Dog Clip and Chain
Part Ref: DCC



Palm Dummy Coupling
Part Ref: PALMDC



PALM COUPLINGS



Part Ref	Thread
----------	--------

PALM7	1/2"
PALM16	M16 x 1.5 mm
PALM22	M22 x 1.5 mm

Part Ref: PALMSEAL



Part Ref: PALMTH
(Top Hat)



Emergency Line

PALM16R	M16 x 1.5 mm
PALM22R	M22 x 1.5 mm

AUTO SELF SEAL



Service Line

PALM16Y	M16 x 1.5 mm
PALM22Y	M22 x 1.5 mm

Part Ref	Thread
----------	--------

PALM16RA	M16 x 1.5 mm
PALM16YA	M16 x 1.5 mm
PALM22RA	M22 x 1.5 mm
PALM22YA	M22 x 1.5 mm

CHANGE OVER PALM COUPLING KITS

PALM TO FEMALE COUPLING



Part Ref: ALC1

1/2" BSP

Part Ref: ALC3

M22 x 1.5 mm

PALM TO MALE COUPLING

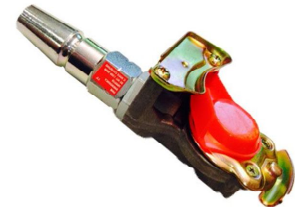

Part Ref: ALC2

1/2" BSP

Part Ref: ALC4

M22 x 1.5 mm

VALVES & FILTERS

Part Ref: PV16HALD

Part Ref: SV16HALD

Part Ref: DCV

Part Ref: ILF22

PARK VALVE - M16

SHUNT VALVE - M16

DOUBLE CHECK - M16

IN LINE FILTER - M22



COUPLING GRIPS - Ref: CG1



Secure grip and more control

Reduce the strain on operator's hands when coupling up the tractor and trailer

Prevent operator's hand slipping

Reduce the risk of injury

Compact design

The Easy-Grip does not interfere with coils during vehicle articulation

Manufactured from tough, durable rubber compound

Virtually indestructible in normal operating conditions

Reusable – simple push-on fit

Transfer to replacement coil in event of coil or 'C' coupling failure

Colour-coded





TEST EQUIPMENT

Test Tool and Gauge - Part Ref: FCTG/IR

- Boxed and complete with gauge.
- The test tool checks the level of lift the female coupling will cause when coupled to male self sealing valve.
- The gauge checks the correct operation of the test tool.

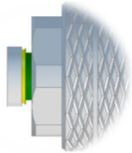

- Double band in indicator section.
- Start of yellow band indicates minimum Requirement of 3mm lift.
- Start of green band indicates preferred level of lift for correct operation - 4mm.
- Used to verify correct manufacture and installation of female service line coupling.
- As supplied to DVSA.

TEST EQUIPMENT

Part Ref: TG2



100 mm Glycerin
Test Gauge
Bottom threaded

0 - 16 Bar
-10 to 70° c



Part Ref: TGRPC

Protective
Rubber
Surround



TEST POINT ADAPTORS (16 mm Female Threads)

ADAPTOR SEALS



WING NUT

Part Ref	Tube ID
TPA1/W	3/16" - 5 mm
TPA2/W	1/4" - 7 mm
TPA3/W	3/8" - 10 mm



LONG STEM

Part Ref	Tube ID
TPA2L	1/4" - 7 mm
TPA3L	3/8" - 10 mm



Part Ref:
TPAC

Air Line Hose
Section 16 -
Page 3



'O' Clips
Section 8 -
Page 3



TEST EQUIPMENT KITS

Enables you to identify the air pressure from any given Test Point

Enables you to determine the air pressure from Truck to Trailer



- Pre MOT Testing
- Faulty Valve Indication
- Calibration
- Load Sensing Valve Testing
- Balancing Air Pressure



Part Ref: ETB001V

CONTENTS OF KIT:

Two 16 Bar gauges (TG2) measuring psi/bar and vacuum

Test coupling tee-piece / Service-line coupling tester (FCTG/IR)

Two x 2 mtr Hoses complete with Test Point Adaptors



Part Ref: ABC009

CONTENTS OF KIT:

Single 16 Bar Gauge (TG2)

Two x Coupling Testers

One x 2 mtr hose complete with test point adaptors

CARRY CASES

Part Ref:
TBG2

*Holds up to 2
Gauges & Hoses*

Part Ref:
TBG3

*Holds up to 3
Gauges & Hoses*



HOSES



**GAUGE
COMPLETE
WITH 5 METRE
HOSE**

Part Ref:
TG25M

**GAUGE HOSE 2
METRE
C/W adaptors**

Part Ref: GH2M



** Colours may vary **

SECTION

19

SIRIT COMPACT RELEASABLE FITTINGS



CHARACTERISTICS AND SCOPE OF USE

The SIRIT-RTC rapid connection joints have been designed for use with 11/12 (Rilsan), 10/12 polyamide or elastomeric polyester (Hyltel) pipes. Prompted by the market requirements, TOSI - SIRIT has decided to design a single joint able to recover the pipe after insertion, thanks to the RTC TOOL (RTC TOOL) on page 2.

The pipe tolerances and characteristics must strictly comply with the following rules:
DIN 74324, DIN 73378, ISO 7628 and SAE J844.

No other pipe type can be used unless previously authorised by TOSI F.lli S.r.l.

SIRIT-RTC joints are generally manufactured with the following materials: EN 12164 CW614 N (CuZn39Pb3), EN 12165 CW617 N (CuZn40Pb2), PA 66 GF30, PA 6.10 GF30, EPDM, NBR.

The estimated thermal tight seal of the threads is estimated to be between +100°C and -40°C with max. pressure of 15bar.

The seal of the joint threaded part complies with rules ISO 6149 and DIN 3852.

The joint has been designed for use with air and is therefore unsuitable for use with other fluids/gas unless specifically authorised by TOSI F.lli srl.

SIRIT COMPACT RELEASABLE FITTINGS



RECOVERY OF THE PIPE



- Position the RTC TOOL with SIDE B oriented towards the upper-ring and then join together the two semi-spheres around the pipe.



- Put pressure on the sides of the two semi-spheres to join them together around the pipe.



- Press strongly on the two semi-spheres inside the upper-ring and pull out the pipe

RELEASE TOOLS

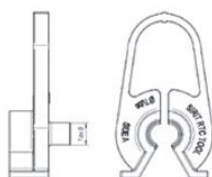

PLASTIC

Part Ref	Tube OD
RT6	6 mm
RT8	8 mm
RT10	10 mm
RT12	12 mm
RT15	15 mm
RT16	16 mm

ALUMINIUM

Part Ref	Tube OD
RT6M	6 mm
RT8M	8 mm
RT10M	10 mm
RT12M	12 mm
RT15M	15 mm
RT16M	16 mm

SIRIT COMPACT RELEASABLE FITTINGS

MALE STUDS RS800 SERIES

Part Ref	Thread Size	Tube Size	TYPE
----------	-------------	-----------	------

RS800210	M10 x 1	6 x 1	A
RS800212	M12 x 1.5	6 x 1	A
RS800214	M14 x 1.5	6 x 1	A
RS800216	M16 x 1.5	6 x 1	B
RS800222	M22 x 1.5	6 x 1	B

RS800310	M10 x 1	8 x 1	A
RS800312	M12 x 1.5	8 x 1	A
RS800314	M14 x 1.5	8 x 1	A
RS800316	M16 x 1.5	8 x 1	B
RS800322	M22 x 1.5	8 x 1	B

RS800412	M12 x 1.5	10 x 1.25	A
RS800416	M16 x 1.5	10 x 1.25	A
RS800422	M22 x 1.5	10 x 1.25	B

TYPE A



TYPE B



Part Ref	Thread Size	Tube Size	TYPE
----------	-------------	-----------	------

RS800416/5	M16 x 1.5	10 x 1.25	A
RS800422/5	M22 x 1.5	10 x 1.25	B

RS800512	M12 x 1.5	12 x 1.5	A
RS800516	M16 x 1.5	12 x 1.5	A
RS800522	M22 x 1.5	12 x 1.5	B

RS800616	M16 x 1.5	15 x 1.5	A
RS800622	M22 x 1.5	15 x 1.5	A
RS800626	M26 x 1.5	15 x 1.5	A

RS800716	M16 x 1.5	16 x 2	A
RS800722	M22 x 1.5	16 x 2	A
RS800726	M26 x 1.5	16 x 2	A

STUD ELBOWS RS810 SERIES

Part Ref	Thread Size	Tube Size
----------	-------------	-----------

RS810210	M10 x 1	6 x 1
RS810212	M12 x 1.5	6 x 1
RS810214	M14 x 1.5	6 x 1
RS810216	M16 x 1.5	6 x 1
RS810222	M22 x 1.5	6 x 1

RS810310	M10 x 1	8 x 1
RS810312	M12 x 1.5	8 x 1
RS810314	M14 x 1.5	8 x 1
RS810316	M16 x 1.5	8 x 1
RS810322	M22 x 1.5	8 x 1



Part Ref	Thread Size	Tube Size
----------	-------------	-----------

RS810412	M12 x 1.5	10 x 1.25
RS810416	M16 x 1.5	10 x 1.25
RS810422	M22 x 1.5	10 x 1.25
RS810412\5	M12 x 1.5	10 x 1.5
RS810416\5	M16 x 1.5	10 x 1.5
RS810422\5	M22 x 1.5	10 x 1.5

RS810512	M12 x 1.5	12 x 1.5
RS810516	M16 x 1.5	12 x 1.5
RS810522	M22 x 1.5	12 x 1.5

RS810616	M16 x 1.5	15 x 1.5
RS810622	M22 x 1.5	15 x 1.5

RS810716	M16 x 1.5	16 x 2
RS810722	M22 x 1.5	16 x 2



**SOME SIZES MAY
BE 2 PIECE**

SIRIT COMPACT RELEASABLE FITTINGS

STUD RUN TEES RS820 SERIES



Part Ref	Thread Size	Tube Size
RS820210	M10 x 1	6 x 1
RS820212	M12 x 1.5	6 x 1
RS820216	M16 x 1.5	6 x 1
RS820222	M22 x 1.5	6 x 1
RS820310	M10 x 1	8 x 1
RS820312	M12 x 1.5	8 x 1
RS820316	M16 x 1.5	8 x 1
RS820322	M22 x 1.5	8 x 1
RS820412	M12 x 1.5	10 x 1.25
RS820416	M16 x 1.5	10 x 1.25
RS820422	M22 x 1.5	10 x 1.25
RS820512	M12 x 1.5	12 x 1.5
RS820516	M16 x 1.5	12 x 1.5
RS820522	M22 x 1.5	12 x 1.5
RS820616	M16 x 1.5	15 x 1.5
RS820622	M22 x 1.5	15 x 1.5
RS820716	M16 x 1.5	16 x 2
RS820722	M22 x 1.5	16 x 2

STUD TEES RS830 SERIES



Part Ref	Thread Size	Tube Size
RS830210	M10 x 1	6 x 1
RS830212	M12 x 1.5	6 x 1
RS830216	M16 x 1.5	6 x 1
RS830222	M22 x 1.5	6 x 1
RS830310	M10 x 1	8 x 1
RS830312	M12 x 1.5	8 x 1
RS830316	M16 x 1.5	8 x 1
RS830322	M22 x 1.5	8 x 1
RS830412	M12 x 1.5	10 x 1.25
RS830416	M16 x 1.5	10 x 1.25
RS830422	M22 x 1.5	10 x 1.25
RS830512	M12 x 1.5	12 x 1.5
RS830516	M16 x 1.5	12 x 1.5
RS830522	M22 x 1.5	12 x 1.5
RS830616	M16 x 1.5	15 x 1.5
RS830622	M22 x 1.5	15 x 1.5
RS830716	M16 x 1.5	16 x 2
RS830722	M22 x 1.5	16 x 2



SOME SIZES MAY
BE ASSEMBLED



SIRIT COMPACT RELEASABLE FITTINGS

45° DEGREE ELBOW RS840 SERIES



Part Ref	Thread Size	Tube Size
RS840216	M16 x 1.5	6 x 1
RS840222	M22 x 1.5	6 x 1
RS840316	M16 x 1.5	8 x 1
RS840322	M22 x 1.5	8 x 1
RS840416	M16 x 1.5	10 x 1.25
RS840422	M22 x 1.5	10 x 1.25
RS840516	M16 x 1.5	12 x 1.5
RS840522	M22 x 1.5	12 x 1.5
RS840616	M16 x 1.5	15 x 1.5
RS840622	M22 x 1.5	15 x 1.5
RS840716	M16 x 1.5	16 x 2
RS840722	M22 x 1.5	16 x 2

'F' STUD ELBOW RS843 SERIES



Part Ref	Thread Size	Tube Size
RS843216	M16 x 1.5	6 x 1
RS843222	M22 x 1.5	6 x 1
RS843316	M16 x 1.5	8 x 1
RS843322	M22 x 1.5	8 x 1
RS843416	M16 x 1.5	10 x 1.25
RS843422	M22 x 1.5	10 x 1.25
RS843516	M16 x 1.5	12 x 1.5
RS843522	M22 x 1.5	12 x 1.5
RS843616	M16 x 1.5	15 x 1.5
RS843622	M22 x 1.5	15 x 1.5
RS843716	M16 x 1.5	16 x 2
RS843722	M22 x 1.5	16 x 2

FIXED CROSS RS841 SERIES



Part Ref	Thread Size	Tube Size
RS841216	M16 x 1.5	6 x 1
RS841222	M22 x 1.5	6 x 1
RS841316	M16 x 1.5	8 x 1
RS841322	M22 x 1.5	8 x 1

Part Ref	Thread Size	Tube Size
RS841416	M16 x 1.5	10 x 1.25
RS841422	M22 x 1.5	10 x 1.25
RS841516	M16 x 1.5	12 x 1.5
RS841522	M22 x 1.5	12 x 1.5
RS841616	M16 x 1.5	15 x 1.5
RS841622	M22 x 1.5	15 x 1.5
RS841716	M16 x 1.5	16 x 2
RS841722	M22 x 1.5	16 x 2

SIRIT COMPACT RELEASABLE FITTINGS

STUD RUN TEST POINT TEES

RS821 SERIES



Part Ref	Thread Size	Tube Size	Part Ref	Thread Size	Tube Size
RS821212	M12 x 1.5	6 x 1	RS821512	M12 x 1.5	12 x 1.5
RS821216	M16 x 1.5	6 x 1	RS821516	M16 x 1.5	12 x 1.5
RS821222	M22 x 1.5	6 x 1	RS821522	M22 x 1.5	12 x 1.5
RS821312	M12 x 1.5	8 x 1	RS821616	M16 x 1.5	15 x 1.5
RS821316	M16 x 1.5	8 x 1	RS821622	M22 x 1.5	15 x 1.5
RS821322	M22 x 1.5	8 x 1	RS821716	M16 x 1.5	16 x 2
RS821412	M12 x 1.5	10 x 1.25	RS821722	M22 x 1.5	16 x 2
RS821416	M16 x 1.5	10 x 1.25			
RS821422	M22 x 1.5	10 x 1.25			

TEST POINT TEES

RS823 SERIES



Part Ref	Thread Size	Tube Size	Part Ref	Thread Size	Tube Size
RS823212	M12 x 1.5	6 x 1	RS823512	M12 x 1.5	12 x 1.5
RS823216	M16 x 1.5	6 x 1	RS823516	M16 x 1.5	12 x 1.5
RS823222	M22 x 1.5	6 x 1	RS823522	M22 x 1.5	12 x 1.5
RS823312	M12 x 1.5	8 x 1	RS823616	M16 x 1.5	15 x 1.5
RS823316	M16 x 1.5	8 x 1	RS823622	M22 x 1.5	15 x 1.5
RS823322	M22 x 1.5	8 x 1	RS823716	M16 x 1.5	16 x 2
RS823412	M12 x 1.5	10 x 1.25	RS823722	M22 x 1.5	16 x 2
RS823416	M16 x 1.5	10 x 1.25			
RS823422	M22 x 1.5	10 x 1.25			

STUD TEST POINT TEES

RS831 SERIES



Part Ref	Thread Size	Tube Size	Part Ref	Thread Size	Tube Size
RS831212	M12 x 1.5	6 x 1	RS831512	M12 x 1.5	12 x 1.5
RS831216	M16 x 1.5	6 x 1	RS831516	M16 x 1.5	12 x 1.5
RS831222	M22 x 1.5	6 x 1	RS831522	M22 x 1.5	12 x 1.5
RS831312	M12 x 1.5	8 x 1	RS831616	M16 x 1.5	15 x 1.5
RS831316	M16 x 1.5	8 x 1	RS831622	M22 x 1.5	15 x 1.5
RS831322	M22 x 1.5	8 x 1	RS831716	M16 x 1.5	16 x 2
RS831412	M12 x 1.5	10 x 1.25	RS831722	M22 x 1.5	16 x 2
RS831416	M16 x 1.5	10 x 1.25			
RS831422	M22 x 1.5	10 x 1.25			

SIRIT COMPACT RELEASABLE FITTINGS

STUD BULK HEAD - RS803 SERIES

Part Ref	Thread Size	Tube Size
RS803216	M16 x 1.5	6 x 1
RS803222	M22 x 1.5	6 x 1
RS803316	M16 x 1.5	8 x 1
RS803322	M22 x 1.5	8 x 1
RS803416	M16 x 1.5	10 x 1.25
RS803422	M22 x 1.5	10 x 1.25



Part Ref	Thread Size	Tube Size
RS803516	M16 x 1.5	12 x 1.5
RS803522	M22 x 1.5	12 x 1.5
RS803616	M16 x 1.5	15 x 1.5
RS803622	M22 x 1.5	15 x 1.5
RS803716	M16 x 1.5	16 x 2
RS803722	M22 x 1.5	16 x 2

STRAIGHT JOINERS - RS850 SERIES



Part Ref	Tube Size
RS850200	6 x 1
RS850300	8 x 1
RS850400	10 x 1.25
RS850500	12 x 1.5
RS850600	15 x 1.5
RS850700	16 x 2

ELBOW JOINERS - RS860 SERIES



Part Ref	Tube Size
RS860200	6 x 1
RS860300	8 x 1
RS860400	10 x 1.25
RS860500	12 x 1.5
RS860600	15 x 1.5
RS860700	16 x 2

TEE JOINERS - RS870 SERIES



Part Ref	Tube Size
RS870200	6 x 1
RS870300	8 x 1
RS870400	10 x 1.25
RS870500	12 x 1.5
RS870600	15 x 1.5
RS870700	16 x 2

CROSS JOINERS - RS880 SERIES



Part Ref	Tube Size
RS880200	6 x 1
RS880300	8 x 1
RS880400	10 x 1.25
RS880500	12 x 1.5
RS880600	15 x 1.5
RS880700	16 x 2

SIRIT COMPACT RELEASABLE FITTINGS

SWIVEL COMPONENTS

SWIVEL ELBOW



Part Ref	Tube Size
RS815200	6 x 1
RS815300	8 x 1
RS815400	10 x 1.25
RS815500	12 x 1.5
RS815600	15 x 1.5
RS815700	16 x 2

SWIVEL TEE



Part Ref	Tube Size
RS825200	6 x 1
RS825300	8 x 1
RS825400	10 x 1.25
RS825500	12 x 1.5
RS825600	15 x 1.5
RS825700	16 x 2

SWIVEL STUD TEE



Part Ref	Tube Size
RS835200	6 x 1
RS835300	8 x 1
RS835400	10 x 1.25
RS835500	12 x 1.5
RS835600	15 x 1.5
RS835700	16 x 2

SWIVEL ELBOW RS845 SERIES



Part Ref	Tube Size
RS845200	6 x 1
RS845300	8 x 1
RS845400	10 x 1.25
RS845500	12 x 1.5
RS845600	15 x 1.5
RS845700	16 x 2

SWIVEL ELBOW RS846 SERIES



Part Ref	Tube Size
RS846200	6 x 1
RS846300	8 x 1
RS846400	10 x 1.25
RS846500	12 x 1.5
RS846600	15 x 1.5
RS846700	16 x 2

SWIVEL ELBOW RS847 SERIES



Part Ref	Tube Size
RS847200	6 x 1
RS847300	8 x 1
RS847400	10 x 1.25
RS847500	12 x 1.5
RS847600	15 x 1.5
RS847700	16 x 2

SIRIT COMPACT RELEASABLE FITTINGS

SWIVEL COMPONENTS

SWIVEL ELBOW RS848 SERIES



Part Ref	Tube Size
RS845200	6 x 1
RS845300	8 x 1
RS845400	10 x 1.25
RS845500	12 x 1.5
RS845600	15 x 1.5
RS845700	16 x 2

SWIVEL ELBOW RS849 SERIES



Part Ref	Tube Size
RS846200	6 x 1
RS846300	8 x 1
RS846400	10 x 1.25
RS846500	12 x 1.5
RS846600	15 x 1.5
RS846700	16 x 2

SWIVEL ELBOW RS851 SERIES



Part Ref	Tube Size
RS847200	6 x 1
RS847300	8 x 1
RS847400	10 x 1.25
RS847500	12 x 1.5
RS847600	15 x 1.5
RS847700	16 x 2



All fittings in throughout the ranges are available to 10 x 1.5 mm also

SWIVEL TIPO STUDS



Part Ref	Thread
660502	1/8"
660504	1/4"
660510	M10 x 1
660512	M12 x 1.5
660514	M14 x 1.5
660516	M16 x 1.5
660522	M22 x 1.5
660526	M26 x 1.5

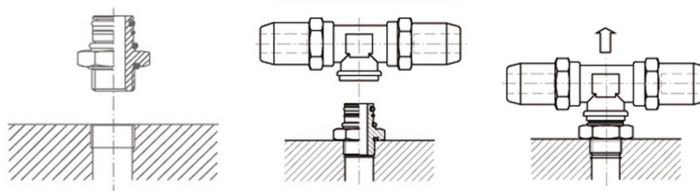

Screw the swivel coupling into the thread ensuring correct torque

(overtightening can cause damage to both the fitting and the component).

Then fit the component by means of push and twist.

IMPORTANT:

Check the component is coupled properly.

Pull the component to ensure this is the case.

DISPLAY PACKS & RACKING

Air Brake Connections display packets are fully re-usable using a sliding back card (Heavy Grade) to a transparent fitted display pack which securely holds all the parts inside.



Each packet is clearly labelled with part numbers and descriptions at the bottom of each pack and also the pack quantity.



This is a really simple way to stock parts which are visible to a customer at the point of sale in all customer counter areas.

Our most popular racking is a wall mountable hanging system. This comprises of a fixed secure top rack and a simple floating hook-on drop of rows. Each part of the system has two rows and has space for 16 slide in euro hooks (8 per row), and we suggest a maximum of 5 packets per hook. This is all topped off with an Air Brake Connections Board

We also supply fully rotational stands using the same hook on system.

Bespoke Systems and products are also available to suit any requirements upon request.



The re-order cards we issue should be placed behind the packs making it easy for restocking replacements and keeping all packets in order.

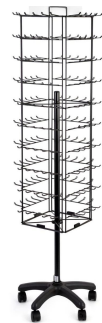

Please visit www.airbrakeconnections.co.uk for a full listing of the display pack part numbers or refer to our current price list. This will also have the information of the pack quantities. Alternatively please do not hesitate to give us a call for any more information you require.

To order in Display Packs is also very easy by simply adding a 'DIS' to the part that you require. For example:



800316 = DIS800316





Conditions of Sale

1: **IN GENERAL** – These conditions of sale shall be applied as conditions in any order or contract accepted by us. No agent, stockist, third party or an employee other than director of the company selling our products is authorised to transact any business, which gives any warranty, or any representation, or incurs any liability on our behalf. We reserve the right to change our products, their design or construction details without prior notice. If these conditions or any other conditions to which another party may seek to incorporate into the contract conflict, these conditions shall prevail. Any notice required to be served pursuant to these conditions should be served as follows:

1/1: The Seller. Air Brake Connections International Ltd address as registered office.

1/2: The Buyer. To the address as notified to the seller or in case of default or notification to the address from which the products and or services were ordered. Or to the registered offices of the buyer. An addressed notice sent via first class post to those destinations within the UK or the Republic of Ireland shall be expected as having been received three days after the day of despatch. An addressed notice of any other destination via Air mail shall be expected as having been received seven days after the date of despatch.

2: **DISTRIBUTION** – The method of distribution shall be decided by ABC Ltd and all goods went be sent carriage free except in the case of:

2/1: Any mainland UK order below a nett value of £150.00.

2/2: Any Non mainland UK (Scotland, N. Ireland) order below a nett value of £200.00.

2/3: Any Southern Ireland order below a nett value of €250.00.

2/4: Any special orders placed upon ABC for which any carriage charges incurred by ABC shall be charged to our customer in full.

2/5: Orders despatched on customers instructions by any means more expensive than our normal chosen method.

3: **DESCRIPTIONS** – While every effort has been made to ensure that the products are accurately described and we believe to be fit for the purpose as described in our catalogues leaflets, wall charts, etc. We give no warranty or representation to this effect. We also take no responsibility in the event of any error or misdescription of any such unfit, or any damage relating there from. Photographs, illustrations, etc and technical information generally represent the goods or products offered for sale but are not binding in detail. ABC reserve the absolute right to make detailed alterations to the materials and specifications, weights, dimensions, etc.

4: **DELIVERY VIA SCHEDULE** – Delivery of orders via schedules made at scheduled rate to which on the following conditions:

4/1: No delay of delivery can be taken unless the customer has agreed or ABC prior and or has written agreement.

4/2: Delay of any schedule or delivery months from the originally agreed not be accepted.

4/3: ABC require and reserve the right to insist that fourteen days notice must be given to delay firm orders or schedules.

4/4: Each delivery constitutes a separate transaction. Quantities delivered in each time scale within the schedules will be subject to a tolerance agreed to prior between ABC and their customers.

5: **DELIVERY QUOTATIONS** – Delivery dates quoted for despatch is subject to stock remaining old sold. Should we be delayed or prevented from delivering the whole or part of our customers orders due to circumstances beyond our control our customers shall not be entitled to refuse or to except those goods or products previously ordered unless prior agreement has been sought and agreed.

6: **DISCLAIMER NOTICE** – Where our part reference and or other supplier manufactures references are quoted side by side, this has been done purely for reference only and does not necessarily indicate the manufacturer of said goods or products nor does it have any reflection upon our competitors.

7: **GUARANTEES** – In lieu of such warranty implied or covered by law, we expressly guarantee to replace or make good any products supplied by ABC, which may be defective through faulty materials or workmanship, provided always, that such parts are promptly returned free to our premises within seven working days of the defect having become apparent and not later than six months after the date of delivery having been made by ABC or it chosen carriers.

7/1: ABC will not be liable for any loss incurred through stoppage, nor for any consequential loss or damaged caused.

7/2: ABC guarantee is in respect of material and workmanship only we shall not apply this if injury, or expenditure, However the goods or products are altered or tampered with or if a defect shall be due to or brought about by fair wear and tear., carelessness on the part of the user, misuse or accident, or other cause outside the control of ABC, and providing the customer is not in default of payment of any sums due to ABC. The customer is responsible for ensuring the goods ordered upon us are suitable for the purpose for which they are intended or required for. Te liability under this guarantee is limited to repair and or replacement, in no circumstances whatsoever shall we incur or be liable for any further liability under this guarantee, save where you have dealt with us on a customer basis.

7/3: Any express or implied condition of warranty or term statutory, or otherwise as to the quality fitness, compliance with description, or sample of the whole or part of the goods or products, or any replacement thereof, or as to the quality of any work or repair or replacement is hereby excluded.



8: **INTERPRETATION BY LAW** – These conditions and contracts are governed in all respect by ENGLISH LAW and the customer submits to the jurisdiction of the English Courts.

9: **MINIMUM INVOICING DETAILS** – Due to the ever increasing high costs of processing small value orders our minimum invoice charge will be £40.00 nett excluding the carriage charges. This condition shall not apply to back orders or part orders.

10: **PACKAGING** – ABC reserve the right to charge for export packaging with the prior agreement of export customers.

11: **PRICING** – All prices are subject to alteration without prior notice . If during the currency of any contract or schedule there be an increase in the cost of labour and or materials required in connection with or for the purpose of any such contract or schedule over the cost of such labour and or materials prevailing at the date of acceptance such nett increases of costs may or shall be added to those contracts or schedules prices and shall be payable by our customer. All prices are subject to the addition of VAT when appropriate. Special orders placed with ABC may be subject to a variance from the normal list price. Quotations of price will be given at the time of placing and order and will be deemed to be binding solely for that special order.

12: **RETURN OF GOODS** – All goods or products correctly supplied in accordance with the customers order but which are subsequently refused or returned will only be credited provided that:

Our written agreement has been obtained. We do reserve the right to accept returned goods or products.

Those goods to be credited are contained within our current price list, are of current design, and in condition for resale. Those goods returned must be accompanied by a packing or returns document stating the reason for return. To include the original invoice or despatch note document reference. We reserve the right to charge a 20% handling charge and also the original cost of carriage if incurred. Special orders placed upon ABC will not be accepted as a return unless we have written agreement prior.

13: **RISK, DAMAGE, LOSS, NON DELIVERY** – Risk in the goods or products will pass to customer upon, delivery of the goods to the customers premises or to a third party address as instructed by the customer in respect of a sale to a UK based customer: and delivery F.O.B. UK port in respect of any sale to an overseas based customer unless otherwise agreed between the parties in writing:

14: **TERMS OF PAYMENT** – UK payment by the last working day of the month following the date of invoice, pending ABC opening a credit account all goods must be paid for in advance, and prior to the confirmation of satisfactory trade and or bank references a credit limit of £1000.00 shall be applied. Exports/Overseas: The method of payment shall be determined prior to or at the time of confirmation of the order. Any bank charges on export bills are payable by the customer. ABC reserve the right to charge interest at the rate of 5% per month on extended terms of payment and overdue accounts. All costs incurred during the recovery period of an outstanding debt shall be met by the customer. While any account of one of our customers is overdue the company may withhold or suspend and supply or any contractual obligation to such customers.

15: **TITLE RETENTION** – Property in the goods and or products, services, shall remain with ABC until you have paid to ABC the price of all goods, products, services supplied under the contract for the supply of goods, products, services and all sums owing at any time by you to ABC. On any ground whatsoever (including without prejudice to the generality of the foregoing, all sums owing by you to ABC at any time in respect of any supply of goods, products, or services under any contract) you undertake that in the event that you buy from a party other than ABC supplies of goods that are or were manufactured by or sold by ABC or are similar to such goods if the intention of retaining such goods, products, or services as stock you will clearly mark each of those goods, products, or services in the said supply in order to distinguish each of those goods, products, or services from goods, products, or services sold to you by ABC.

15/1: You irrevocably grant to ABC a licence to enter (by ABC itself or its servants or agents and with or without vehicle) without notice upon lands and or premises owned, used, or occupied by you for the purpose of ABC taking possession on goods, products, services, the property of ABC: and that you agree to render without charge all assistance as ABC may request to ABC and to ABC servants or agents for the purpose of ABC's identifying and taking possession of goods, products, services the property of ABC.



15/2: Subject to always to and without prejudice to above, you are entitled to sell the goods, products, services to a purchaser or purchasers by way of bona fide sale in the ordinary course of business at any time that (and insofar as) ABC shall permit and provided always that your entitlement shall cease immediately and without notice on the occurrence of any one or more of the following events:

- A receiver or administrative receiver is appointed in respect of you or over all or part of your assets or undertaking.
 - You announce that you have ceased or intend to cease to trade.
- You suspend payment of your debts or unable to pay or admit to state your inability to pay your debts as they fall due.
- You dispose or threaten to dispose of all or a material part of your assets whether by one or a series of transactions (other than the sole purpose of and followed by your reconstruction or amalgamation, approved by ABC).
 - You Convene, call or hold a meeting of your creditors or make any arrangement, voluntary arrangement or composition with your creditors.
- Your directors make or state an intention to make or give notice of a proposal in relation to you for a voluntary arrangement under part of the insolvency Act 1986.
 - A petition is presented for your winding up or administration.
- A resolution (other than for the sole purpose of and followed by your reconstruction or amalgamation, approved by ABC) is passed for your voluntary winding up.
 - You are dissolved.
- You suffer the levy or enforcement of any execution, distress, sequestration, detention or the process on any property or premises.
- In the event that you sell goods to a particular purchaser or purchasers in accordance with 15/2, prior you shall sell as principal in relation to the purchaser or purchasers and have no right to commit ABC to any contractual relationship with or liability to the purchaser or purchasers or any other third party.
- You undertake that in the event that you sell any goods supplied by ABC you will sell those goods (of the type required for the particular sale) as have at the material time been longest in your possession.

16: **CUSTOMER CONDITIONS OF PURCHASE** – In all instances ABC's Conditions of Sale stated herein over ride any separate Terms and Conditions of Purchase stated by ABC's customers.

17: **CONSTRUCTION** – If any provisions of this agreement are held to be invalid for any reason then this Agreement shall be read if the invalid provisions had to that extent been deleted and the validity of the remaining provisions of this Agreement shall not be affected hereby.

18: **VARIANCES TO THESE STANDARD CONDITIONS OF SALE** – ABC reserve the right to vary ABC's standard Conditions of Sale as stated herein. Any variation will be notified in writing to individual customers effected by these variances and will only apply in respect of products purchased following such changes and notifications.



FITTING INSTRUCTIONS

The seal of the stud coupling is specified by what is laid down in ISO standard 6149-80 and also DIN standard 3482. To obtain the correct assembly on all terminal fittings it is essential to adhere to the tightening torques shown in the table below:

THREAD TIGHTENING TORQUE

(Nm) \pm 10

M10 x 1	22
M12 x 1.5	24
M14 x 1.5	30
M16 x 1.5	35
M18 x 1.5	36
M22 x 1.5	40
M26 x 1.5	45

The tubing must be cut at the right angles with a maximum tolerance of 12°. Correct assembly is performed only when the tube is inserted touches the end of the tube seat. To be absolutely certain that this is the case it is advisable to mark the depth of the tubing coupling or use the 'X' provided on the DIN tubing.

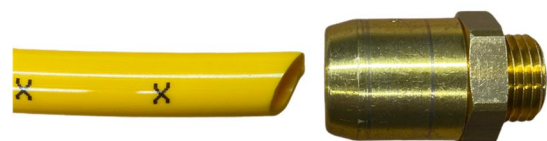



TUBING SIZE	DEPTH OF TUBE mm
6 x 1 mm (4 mm ID)	19.8 mm
8 x 1 mm (6 mm ID)	20.5 mm
10 x 1.5 mm (7 mm ID)	24 mm
10 x 1.25 mm (7.5 mm ID)	24 mm
10 x 1 mm (8 mm ID)	24 mm
12 x 1.5 mm (9 mm ID)	25 mm
15 x 1.5 mm (12 mm ID)	27 mm
16 x 2 mm (12 mm ID)	27 mm
18 x 2 mm (14 mm ID)	27 mm

The tubing or fitting coupling **does not** require tools.
To make the operation easier it is sufficient to slightly turn the tubing when inserting into the fitting. Once the tubing has been fully inserted - Twist the tubing to ensure a full score on the pipe and pull back to guarantee the tubing has been secured and fitted correctly into place. Pulling back confirms it has been fully fitted to the seat of the coupling and not just part clamped onto the internal retaining clip.

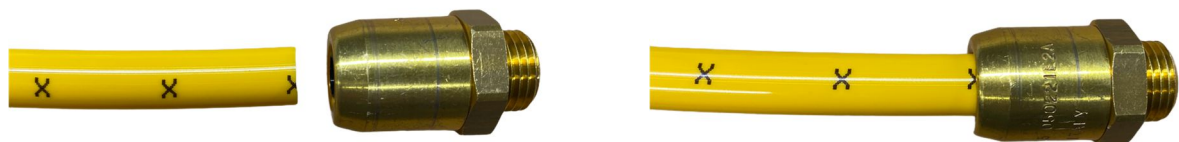

**CHECK THE COMPONENT IS COUPLED
CORRECTLY AND SECURELY.**

PULL THE COMPONENT TO ENSURE



As a guide for final leak testing the fittings, we advise a spray test to take place once the fittings have been pressured to 10 Bar.

Please follow these instructions when fitting.